

技术参数 Technical Data

MTK 7-7I 90w-6P

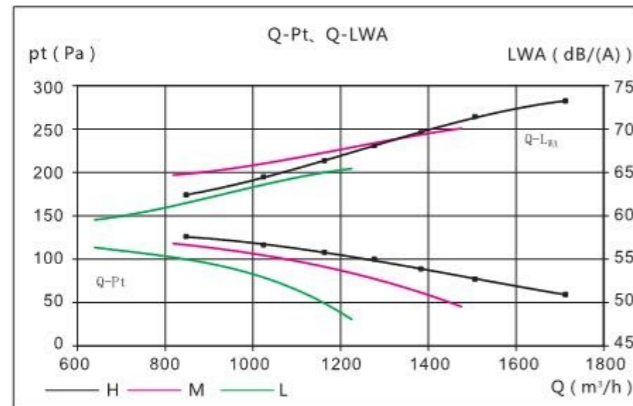

Type: MTK 7-7I	Pn : 90W-6P	U : 220V					
	In : 1.1A	F : 50Hz					
	IP : IP20	m : 8.17Kg					
1/1倍频(H)							
63 Hz	40.9	41.0	42.4	43.8	45.3	45.8	46.4
125 Hz	47.1	47.2	48.6	50.0	51.5	52.0	52.6
250 Hz	53.3	53.9	55.1	56.4	57.7	60.3	62.1
500 Hz	54.3	56.5	58.5	59.7	61.4	62.7	64.0
1K Hz	58.1	60.4	62.3	64.0	65.5	66.6	68.5
2K Hz	55.0	57.2	58.8	60.3	61.7	63.3	65.5
4K Hz	52.5	55.9	58.2	60.6	62.2	64.2	66.3
8K Hz	45.7	47.7	49.6	52.2	54.1	61.3	62.8
Lwa dB(A)	62.4	64.5	66.3	68.1	69.6	71.4	73.2

MTK 7-7I 150w-4P

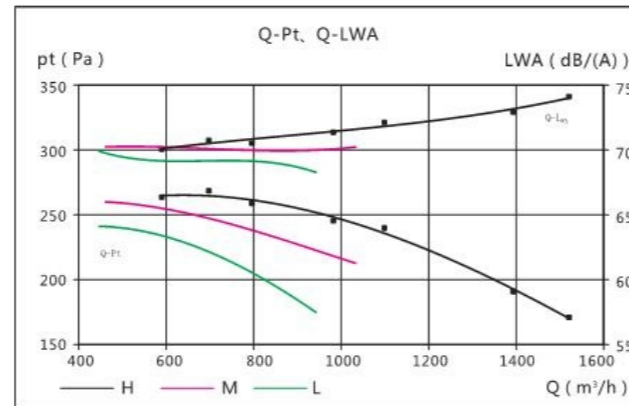

Type: MTK 7-7I	Pn : 150W-4P	U : 220V					
	In : 1.6A	F : 50Hz					
	IP : IP20	m : 9.1Kg					
1/1倍频(H)							
63 Hz	49.2	50.1	48.7	47.9	47.7	48.1	49.0
125 Hz	55.4	56.3	54.9	54.1	53.9	54.3	55.2
250 Hz	62.3	63.5	62.8	62.3	62.7	63.2	64.0
500 Hz	61.2	61.7	61.3	61.6	61.9	63.8	65.1
1K Hz	64.8	65.5	65.3	66.2	67.0	67.9	69.3
2K Hz	62.0	62.5	62.6	64.3	65.6	65.4	66.5
4K Hz	61.2	61.7	61.9	63.7	64.6	65.8	67.0
8K Hz	59.5	59.7	59.7	60.3	60.5	61.3	62.1
Lwa dB(A)	70.1	70.7	70.5	71.4	72.1	72.9	74.1

技术参数 Technical Data

MTK 7-7I 200w-4P

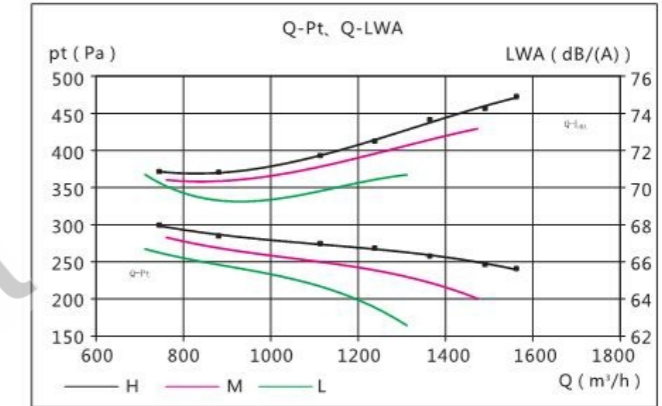

Type: MTK 7-7I	Pn : 200W-4P	U : 220V					
	In : 1.8A	F : 50Hz					
	IP : IP20	m : 9.4Kg					
1/1倍频(H)							
63 Hz	51.5	50.2	48.7	48.5	48.4	48.0	48.6
125 Hz	57.7	56.4	54.9	54.7	54.6	54.2	54.8
250 Hz	64.1	63.4	63.1	64.1	64.6	64.0	64.7
500 Hz	62.2	61.8	62.3	62.8	63.5	64.3	64.8
1K Hz	65.9	66.1	67.3	67.8	69.4	69.8	70.5
2K Hz	62.6	63.0	64.3	65.0	66.0	66.9	67.6
4K Hz	61.5	62.2	63.8	65.0	66.3	67.5	68.1
8K Hz	52.8	53.9	56.1	57.5	59.1	60.5	61.3
Lwa dB(A)	70.9	70.8	71.7	72.5	73.7	74.3	74.9

外形及安装尺寸 Overall size

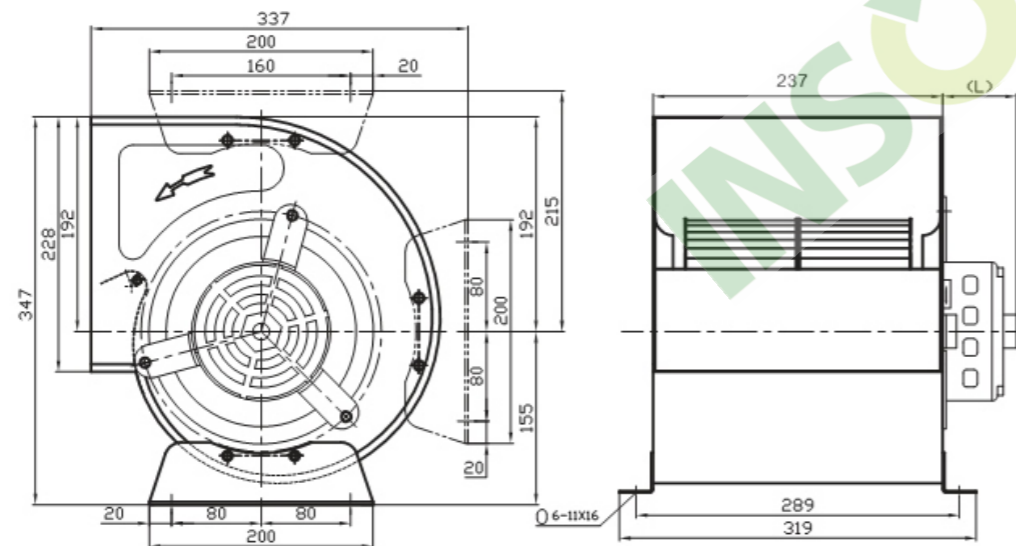

电机功率	Motor Power	90W-6P	150W-4P	200W-4P
L		50	65	65

外形及安装尺寸 Overall size

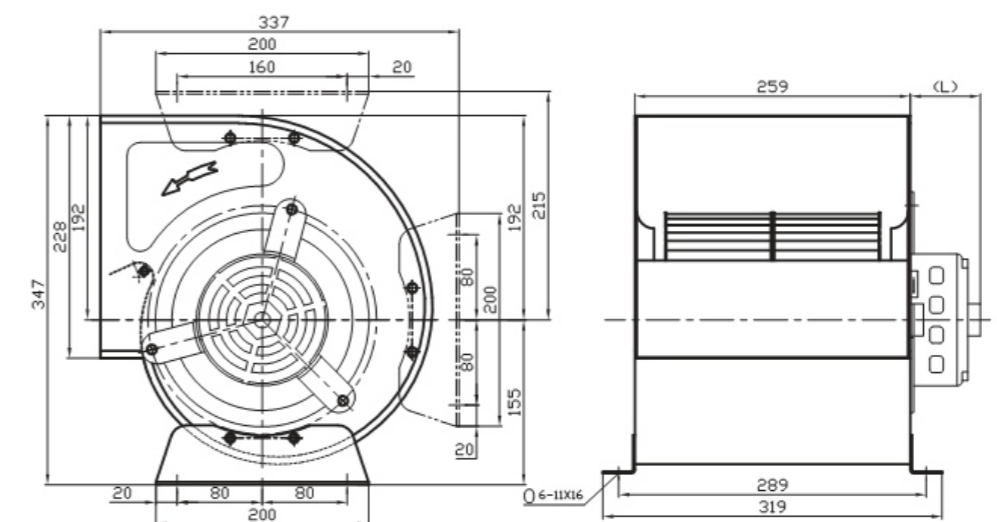

电机功率	Motor Power	90W-6P	150W-4P	200W-4P
L		50	65	65

技术参数 Technical Data

MTK 8-8I 200w-6P

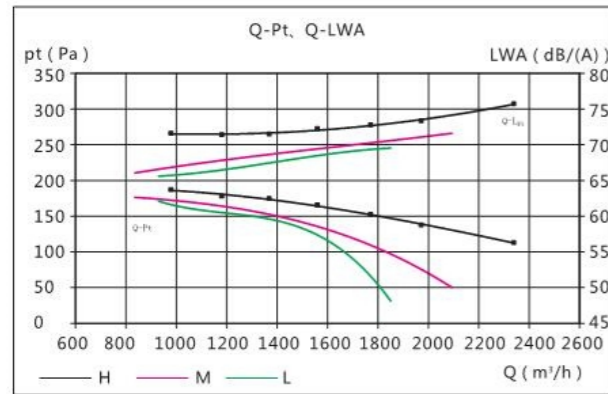

Type: MTK8-8I	Pn : 200W-6P		U : 220V			
	In : 1.8A		F : 50Hz			
	IP : IP20		m : 14.1Kg			
1/1倍频(H)						
63 Hz	49.3	48.6	48.8	49.8	51.3	51.8
125 Hz	55.5	54.8	55.0	56.0	57.5	58.0
250 Hz	62.5	62.3	63.6	64.0	64.7	65.6
500 Hz	60.6	60.4	61.7	63.9	64.0	65.7
1K Hz	68.9	68.5	67.7	67.9	67.8	69.0
2K Hz	63.1	63.5	63.6	64.6	65.5	66.7
4K Hz	58.7	59.8	60.9	62.5	64.4	70.2
8K Hz	56.7	56.9	57.2	58.0	58.9	63.0
Lwa dB(A)	71.6	71.4	71.5	72.3	72.8	75.7

MTK 8-8I 300w-4P

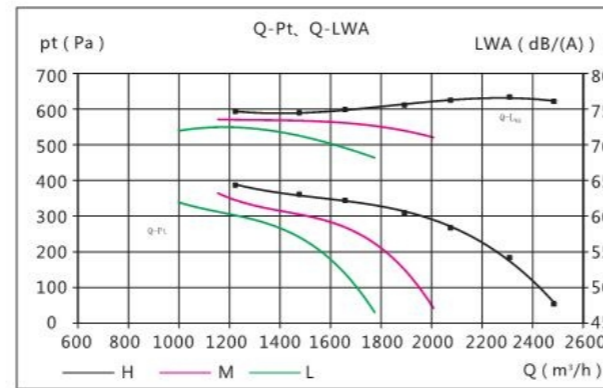

Type: MTK8-8I	Pn : 300W-4P		U : 220V				
	In : 3.7A		F : 50Hz				
	IP : IP20		m : 13.5Kg				
1/1倍频(H)							
63 Hz	55.9	55.3	53.9	54.2	54.9	54.4	52.6
125 Hz	62.1	61.5	60.1	60.4	61.1	60.6	58.8
250 Hz	69.2	67.2	67.9	68.5	68.5	67.4	61.8
500 Hz	65.6	64.9	64.8	64.3	65.3	65.7	65.8
1K Hz	67.4	68.0	68.4	69.1	69.8	70.6	69.8
2K Hz	66.6	67.2	67.8	68.6	69.3	70.0	70.3
4K Hz	66.4	67.3	68.0	69.0	70.0	70.9	70.8
8K Hz	61.0	61.5	61.9	62.9	63.1	64.0	63.3
Lwa dB(A)	74.7	74.5	74.9	75.6	76.2	76.7	76.1

技术参数 Technical Data

MTK 9-7I 150w-6P

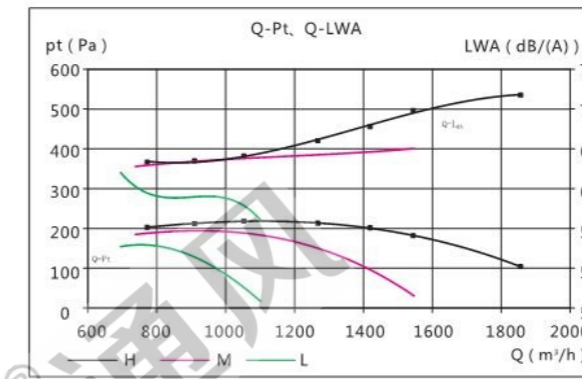

Type: MTK9-7I	Pn : 150W-6P		U : 220V				
	In : 1.4A		F : 50Hz				
	IP : IP20		m : 12.9Kg				
1/1倍频(H)							
63 Hz	45.4	44.6	43.4	43.4	45.8	47.8	49.9
125 Hz	51.6	50.8	49.6	49.6	52.0	54.0	56.1
250 Hz	58.1	58.1	58.1	59.0	59.3	61.8	61.9
500 Hz	57.1	57.0	57.7	59.1	60.6	62.1	63.5
1K Hz	58.9	59.5	59.9	61.4	62.9	64.1	65.6
2K Hz	57.4	57.3	57.9	59.7	61.1	62.4	64.2
4K Hz	54.2	54.7	55.9	58.7	60.6	62.5	64.6
8K Hz	44.2	45.6	46.4	48.8	51.2	53.7	57.1
Lwa dB(A)	64.7	64.8	65.3	66.8	68.2	69.9	71.4

MTK 9-7I 250w-6P

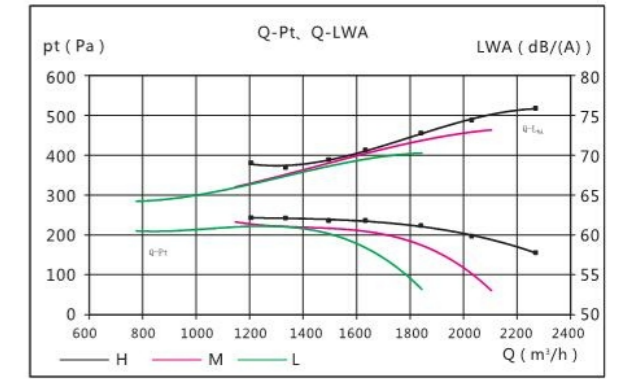

Type: MTK9-7I	Pn : 250W-6P		U : 220V				
	In : 2.1A		F : 50Hz				
	IP : IP20		m : 13.5Kg				
1/1倍频(H)							
63 Hz	47.6	47.2	46.1	46.3	50.8	51.9	52.1
125 Hz	53.8	53.4	52.3	52.5	57.0	58.1	58.3
250 Hz	61.7	59.1	59.2	59.9	62.6	64.0	65.1
500 Hz	60.4	60.0	61.2	62.3	64.2	65.1	66.0
1K Hz	63.8	63.3	64.2	65.4	67.4	69.2	70.3
2K Hz	61.7	61.5	62.6	63.8	65.6	67.3	69.0
4K Hz	60.6	61.0	62.4	63.9	66.0	68.0	69.9
8K Hz	51.6	52.1	53.7	55.6	58.5	61.1	63.4
Lwa dB(A)	69.0	68.5	69.4	70.6	72.7	74.4	75.9

外形及安装尺寸 Overall size

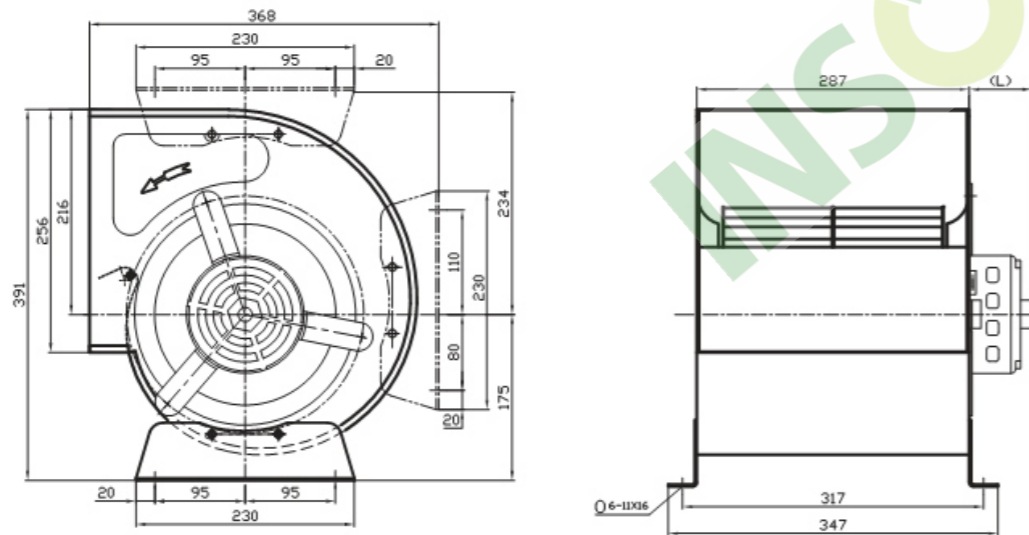

电机功率	Motor Power	200W-6P	300W-4P
L		85	80

外形及安装尺寸 Overall size

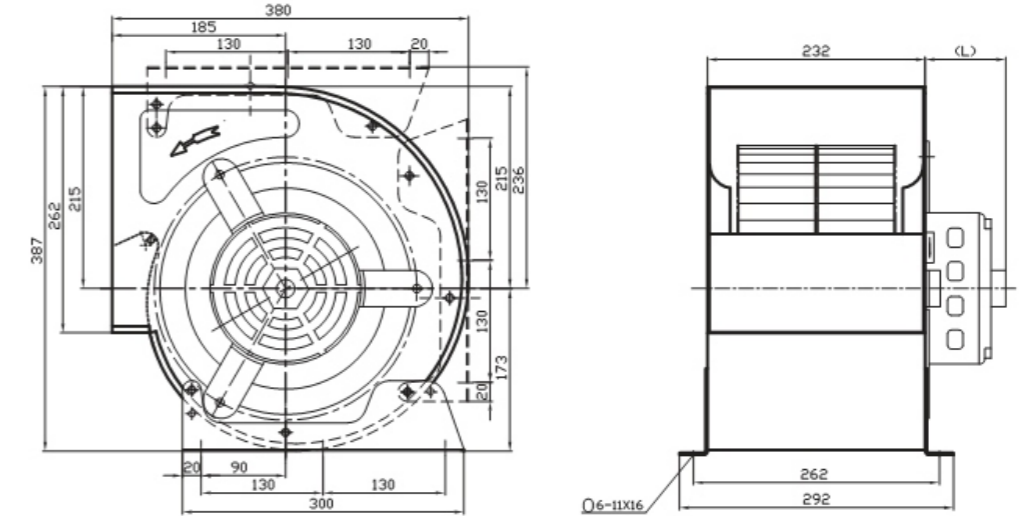

电机功率	Motor Power	250W-6P	150W-6P
L		65	80

电机功率	Motor Power	375W-4P	375W-6P
L		90	90

技术参数 Technical Data

MTK 9-7I 375w-4P

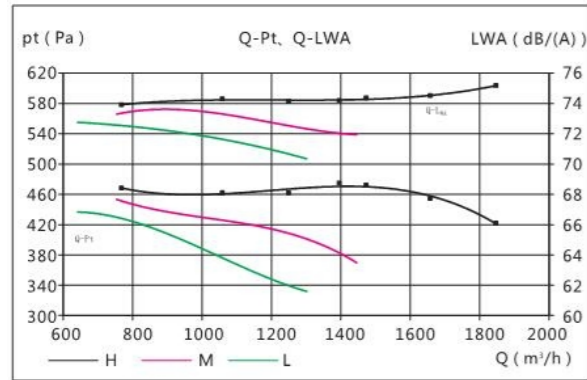

Type:	Pn : 375W-4P	U : 220V					
MTK9-7I	In : 4.2A	F : 50Hz					
	IP : IP20	m : 14.9Kg					
1/1倍频(H)							
63 Hz	56.3	55.2	53.9	51.9	51.5	49.3	49.1
125 Hz	62.5	61.4	60.1	58.1	57.7	55.5	55.3
250 Hz	68.4	67.9	66.8	66.1	65.6	64.1	64.0
500 Hz	66.5	67.0	66.0	66.3	66.6	65.8	65.9
1K Hz	67.2	68.0	68.7	68.6	68.9	69.5	70.3
2K Hz	65.3	65.9	66.1	66.5	66.7	67.2	68.0
4K Hz	63.9	65.4	65.9	66.7	67.0	67.9	68.9
8K Hz	56.1	58.0	58.9	59.6	60.1	60.9	62.1
LWA dB(A)	73.9	74.3	74.1	74.2	74.4	74.5	75.2

MTK 9-7I 375w-6P

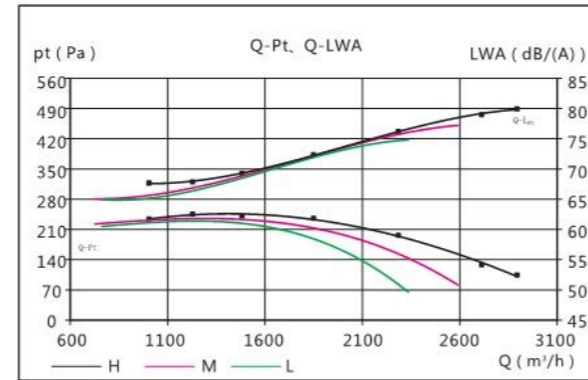

Type:	Pn : 375W-6P	U : 220V					
MTK9-7I	In : 3.5A	F : 50Hz					
	IP : IP20	m : 15.7Kg					
1/1倍频(H)							
63 Hz	48.3	47.4	46.3	46.5	51.8	54.7	56.6
125 Hz	54.5	53.6	52.5	52.7	58.0	60.9	62.8
250 Hz	62.9	61.4	59.6	60.7	65.0	67.8	69.3
500 Hz	58.8	59.4	60.9	63.5	66.3	68.4	69.2
1K Hz	61.2	62.0	64.0	67.1	70.5	73.1	73.9
2K Hz	59.6	60.4	62.4	65.4	69.4	72.1	73.2
4K Hz	57.3	59.3	62.2	66.4	70.5	73.5	74.5
8K Hz	48.2	49.9	53.2	58.7	63.9	67.4	68.2
LWA dB(A)	67.7	67.9	69.3	72.4	76.2	79.0	80.0

技术参数 Technical Data

MTK 9-9I 250w-6P

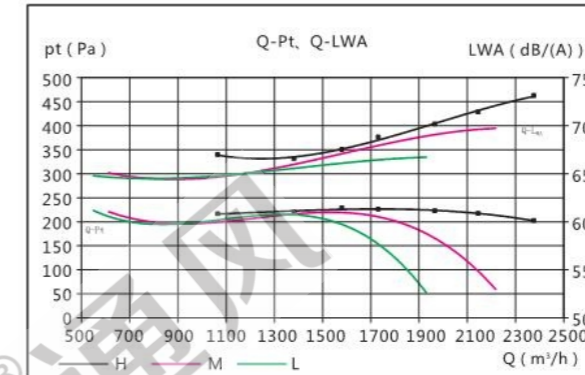

Type:	Pn : 250W-6P	U : 220V					
MTK 9-9I	In : 2.1A	F : 50Hz					
	IP : IP20	m : 14.1Kg					
1/1倍频(H)							
63 Hz	49.7	47.5	46.8	47.6	47.2	47.7	50.9
125 Hz	55.9	53.7	53.0	53.8	53.4	53.9	57.1
250 Hz	61.3	58.9	59.2	59.9	59.9	60.8	61.9
500 Hz	58.0	57.4	58.7	60.2	61.5	62.6	64.2
1K Hz	61.5	61.6	62.3	63.6	64.8	66.0	67.4
2K Hz	59.0	59.9	61.1	62.2	63.7	64.8	66.6
4K Hz	55.6	57.1	59.1	60.9	63.5	65.0	67.0
8K Hz	47.8	47.9	49.2	50.8	53.6	56.0	59.1
LWA dB(A)	67.0	66.6	67.5	68.8	70.2	71.4	73.1

MTK 9-9I 375w-6P

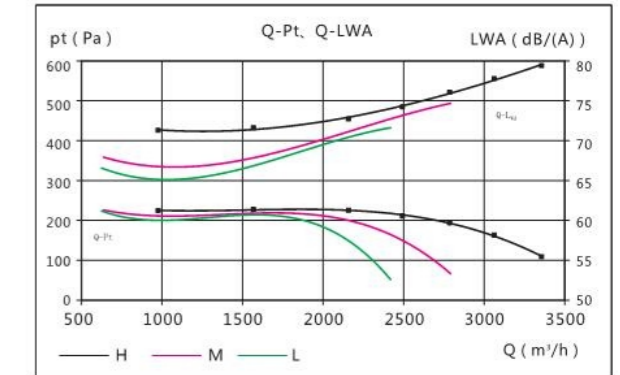

Type:	Pn : 375W-6P	U : 220V					
MTK 9-9I	In : 3.5A	F : 50Hz					
	IP : IP20	m : 16.6Kg					
1/1倍频(H)							
63 Hz	50.6	47.4	49.6	53.0	52.7	53.6	54.7
125 Hz	56.8	53.6	55.8	59.2	58.9	59.8	60.9
250 Hz	68.9	68.0	64.4	63.6	64.8	65.9	67.9
500 Hz	60.6	59.4	63.7	65.2	66.6	68.1	69.2
1K Hz	63.7	65.2	67.4	68.9	70.5	72.0	73.2
2K Hz	60.5	64.0	65.6	67.4	69.5	71.5	73.2
4K Hz	57.7	60.6	65.7	67.7	70.0	72.0	73.9
8K Hz	47.3	49.3	56.0	59.3	62.3	64.5	66.5
LWA dB(A)	71.3	71.6	72.7	74.2	76.1	77.8	79.4

外形及安装尺寸 Overall size

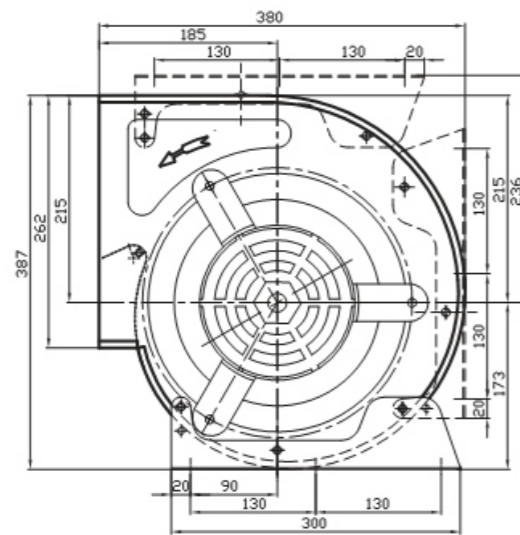

电机功率	Motor Power	250W-6P	150W-6P
L		65	80

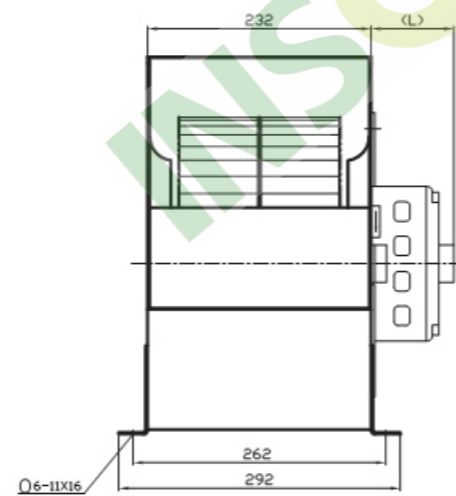

电机功率	Motor Power	375W-4P	375W-6P
L		90	90

外形及安装尺寸 Overall size

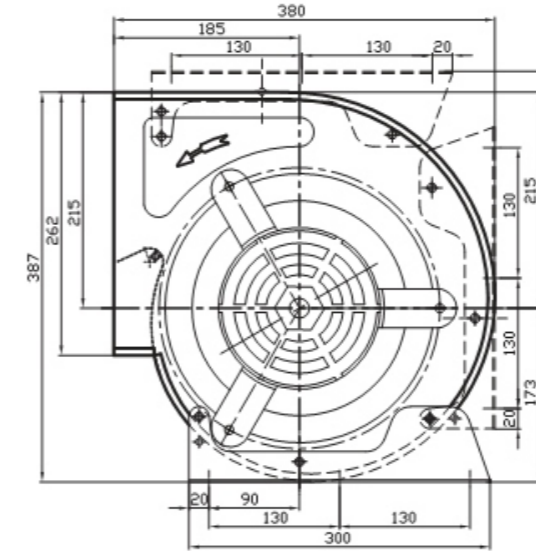

电机功率	Motor Power	250W-6P	375W-6P	450W-4P
L		90	90	95

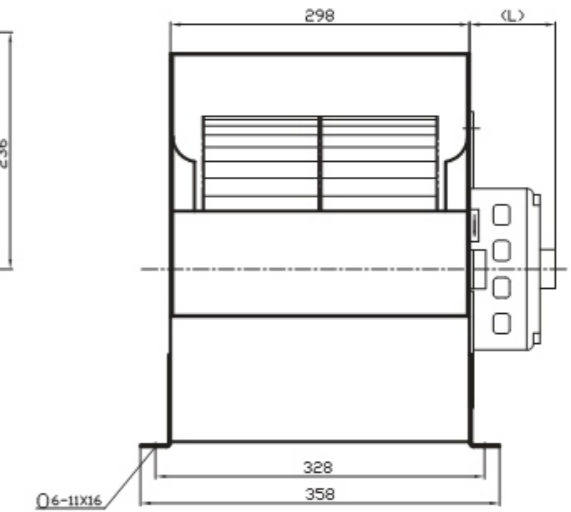

技术参数 Technical Data

MTK 9-9I 375w-4P

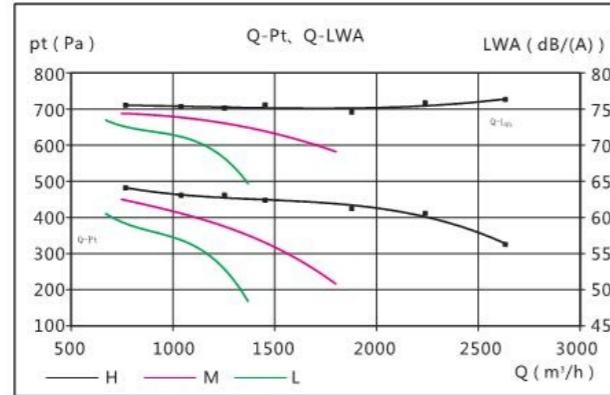

Type:	Pn : 450W-4P		U : 220V				
MTK9-9I	In : 5.0A		F : 50Hz				
	IP : IP20		m : 16.8Kg				
1/1倍频(H)							
63 Hz	58.3	58.8	57.4	57.4	53.7	52.7	52.3
125 Hz	64.5	65.0	63.6	63.6	59.9	58.9	58.5
250 Hz	70.7	70.8	70.1	70.0	67.4	67.1	65.8
500 Hz	66.4	66.0	65.5	66.0	64.6	66.2	66.7
1K Hz	68.8	68.3	68.7	69.4	69.0	70.6	71.0
2K Hz	67.1	66.7	67.2	67.9	67.8	69.3	69.7
4K Hz	65.4	65.0	65.1	66.2	66.7	68.6	69.9
8K Hz	57.3	56.8	56.9	58.0	58.4	60.2	62.2
Lwa dB(A)	75.5	75.3	75.1	75.6	74.6	75.8	76.3

技术参数 Technical Data

MTK 10-8I 375w-6P

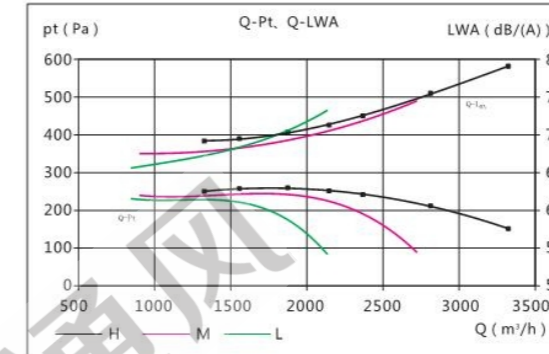

Type:	Pn : 250W-6P		U : 220V				
MTK10-8I	In : 3.5A		F : 50Hz				
	IP : IP20		m : 17.1Kg				
1/1倍频(H)							
63 Hz	55.4	54.9	53.3	52.0	51.4	52.4	53.8
125 Hz	61.6	61.1	59.5	58.2	57.6	58.6	60.0
250 Hz	62.1	61.5	62.3	61.7	62.9	64.1	65.6
500 Hz	60.4	60.8	61.4	62.1	63.3	65.8	68.6
1K Hz	63.0	63.8	64.9	66.0	67.0	70.0	73.3
2K Hz	61.0	61.8	63.1	64.5	66.0	69.4	73.6
4K Hz	59.0	60.2	62.2	64.1	65.7	69.3	73.2
8K Hz	48.6	49.7	52.1	54.5	56.6	61.3	65.7
Lwa dB(A)	69.2	69.5	70.4	71.3	72.5	75.5	79.1

MTK 10-8I 550w-4P

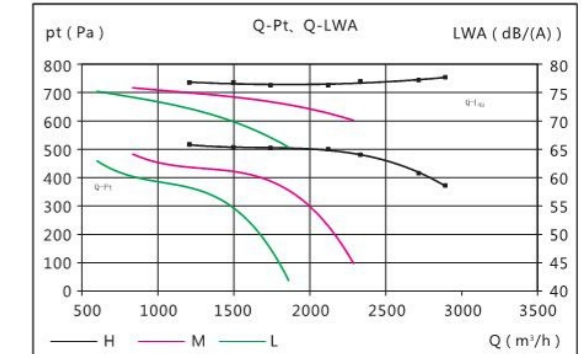

Type:	Pn : 550W-4P		U : 220V				
MTK10-8I	In : 4.9A		F : 50Hz				
	IP : IP20		m : 17.7Kg				
1/1倍频(H)							
63 Hz	59.9	59.9	56.8	53.6	53.9	53.5	53.1
125 Hz	66.1	66.1	63.0	59.8	60.1	59.7	59.3
250 Hz	71.0	71.0	69.3	67.7	67.7	67.3	67.0
500 Hz	67.6	67.6	65.8	65.6	66.0	66.8	67.6
1K Hz	70.3	70.3	70.8	71.5	72.5	72.2	72.8
2K Hz	68.7	68.7	68.8	69.3	69.9	70.5	71.2
4K Hz	67.8	67.8	68.6	69.1	69.8	70.5	71.1
8K Hz	60.0	60.0	61.2	61.7	62.5	63.1	63.6
Lwa dB(A)	76.8	76.8	76.3	76.3	77.0	77.2	77.7

外形及安装尺寸 Overall size

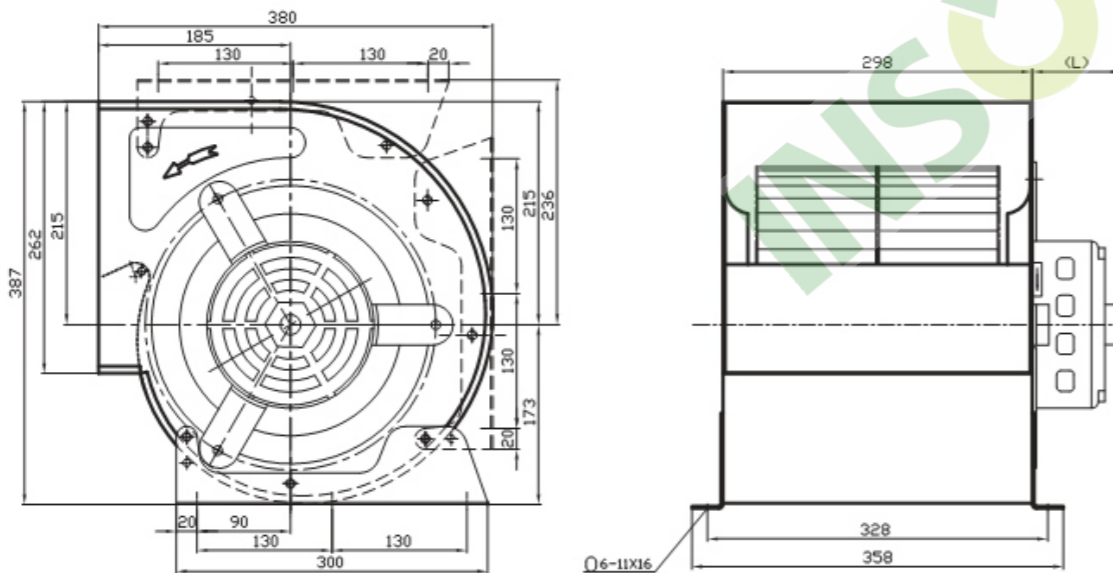

电机功率	Motor Power	250W-6P	375W-6P	450W-4P
L		90	90	95

外形及安装尺寸 Overall size

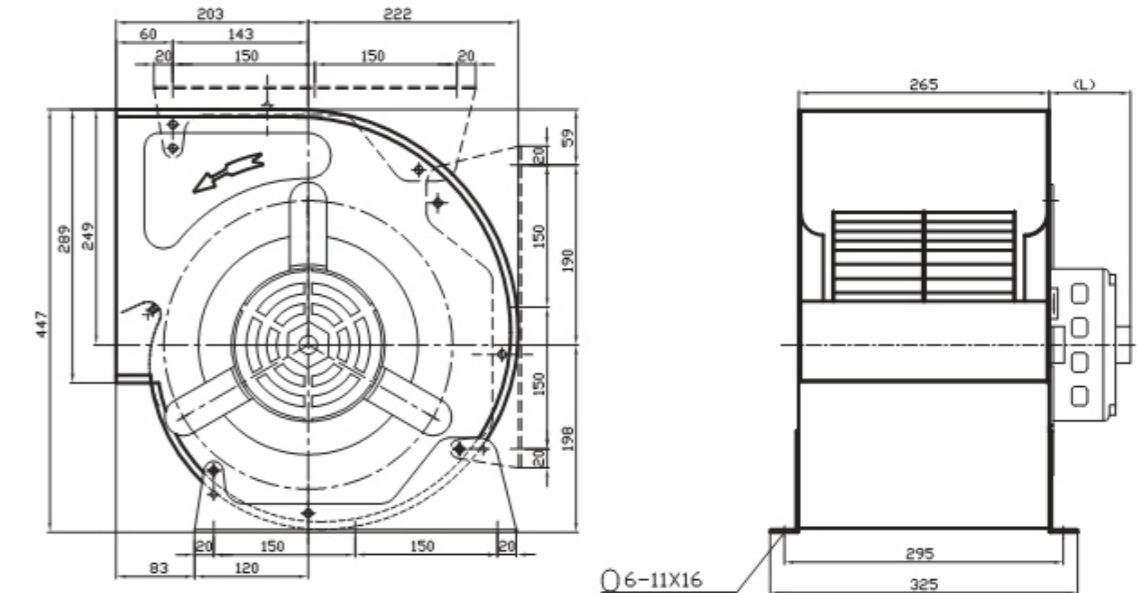

电机功率	Motor Power	375W-6P	550W-4P
L		90	105

技术参数 Technical Data

MTK 10-10I 375w-6P

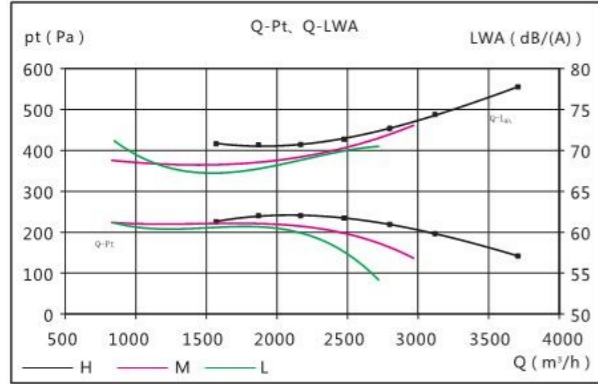

Type: MTK10-10I	Pn : 375W-6P	U : 220V	
	In : 3.5A	F : 50Hz	
	IP : IP20	m : 18.1Kg	
1/1倍频(H)			
63 Hz	58.6	58.8	57.2
125 Hz	64.8	65.0	63.4
250 Hz	63.6	62.2	62.1
500 Hz	61.2	60.4	60.6
1K Hz	63.5	63.9	64.6
2K Hz	61.8	62.3	63.4
4K Hz	61.2	61.3	61.4
8K Hz	55.1	54.0	53.8
LWA dB(A)	70.8	70.7	70.7

MTK 10-10I 450w-6P

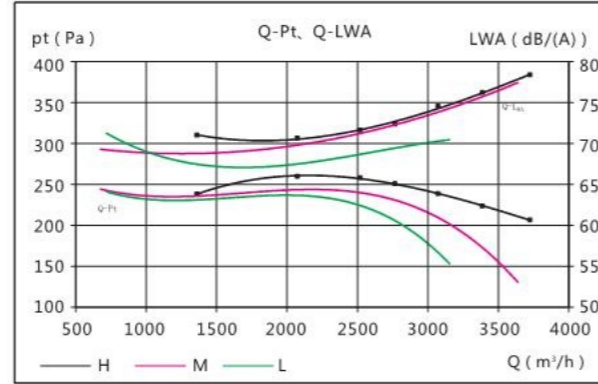

Type: MTK10-10I	Pn : 450W-6P	U : 220V	
	In : 3.5A	F : 50Hz	
	IP : IP20	m : 18.3Kg	
1/1倍频(H)			
63 Hz	58.6	57.7	57.4
125 Hz	64.8	63.9	63.6
250 Hz	72.6	71.8	71.8
500 Hz	68.0	66.8	66.5
1K Hz	70.3	70.1	70.1
2K Hz	70.3	69.6	69.5
4K Hz	68.5	68.3	68.4
8K Hz	61.9	62.1	62.2
LWA dB(A)	77.6	77.0	76.9

技术参数 Technical Data

MTK 10-10I 550w-4P

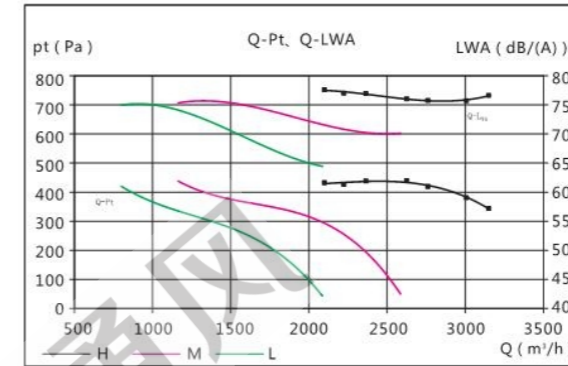

Type: MTK10-10I	Pn : 550W-4P	U : 220V	
	In : 4.9A	F : 50Hz	
	IP : IP20	m : 18.8Kg	
1/1倍频(H)			
63 Hz	58.6	57.7	57.4
125 Hz	64.8	63.9	63.6
250 Hz	72.6	71.8	71.8
500 Hz	68.0	66.8	66.5
1K Hz	70.3	70.1	70.1
2K Hz	70.3	69.6	69.5
4K Hz	68.5	68.3	68.4
8K Hz	61.9	62.1	62.2
LWA dB(A)	77.6	77.0	76.9

MTK 10-10I 550w-6P

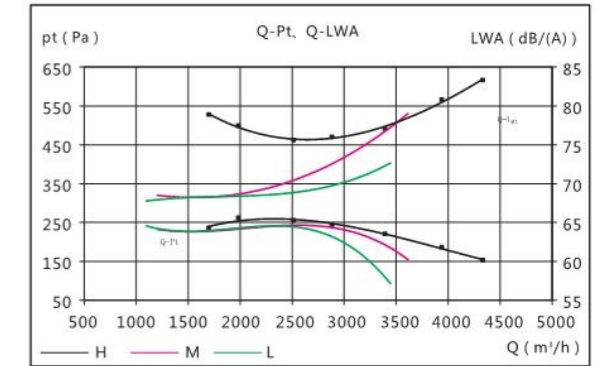

Type: MTK10-10I	Pn : 550W-6P	U : 220V	
	In : 4.7A	F : 50Hz	
	IP : IP20	m : 18.3Kg	
1/1倍频(H)			
63 Hz	59.3	59.3	55.0
125 Hz	65.5	65.5	61.2
250 Hz	65.1	64.2	63.7
500 Hz	64.4	63.9	63.6
1K Hz	75.1	72.3	69.1
2K Hz	68.5	68.4	66.8
4K Hz	71.5	70.8	67.1
8K Hz	71.6	70.5	66.4
LWA dB(A)	78.9	77.4	75.6

外形及安装尺寸 Overall size

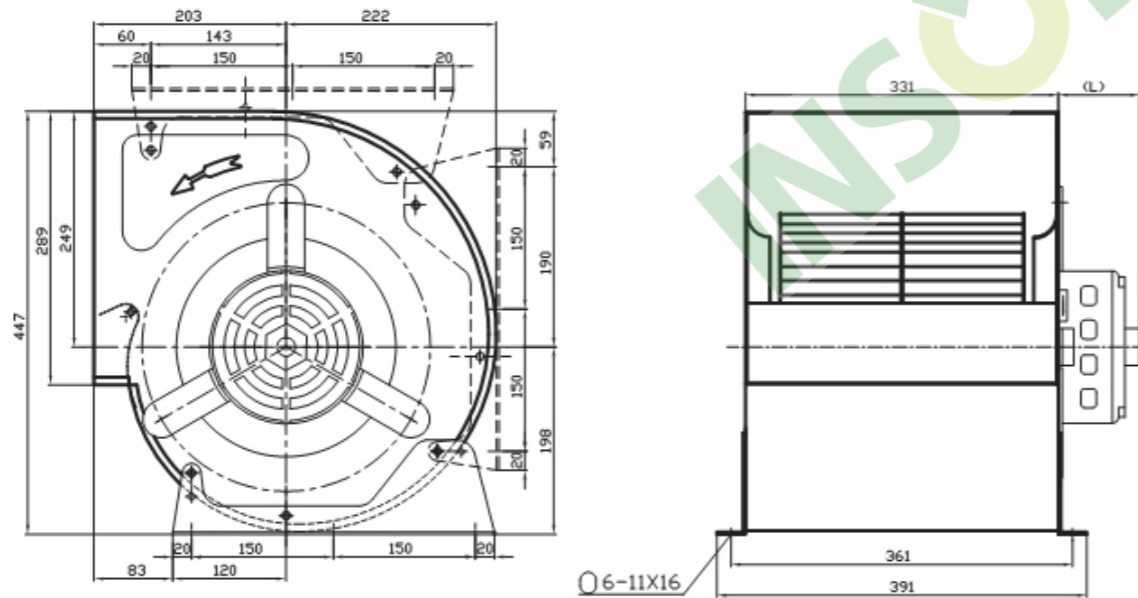

电机功率	Motor Power	375W-6P	550W-4P
L		90	105

电机功率	Motor Power	450W-6P	550W-4P
L		105	105

外形及安装尺寸 Overall size

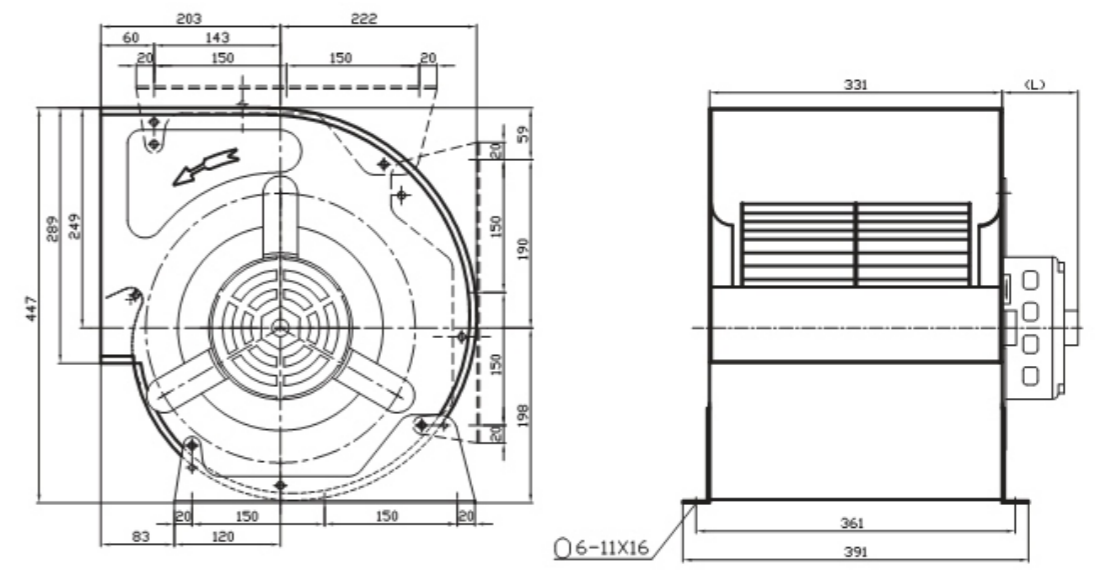

电机功率	Motor Power	375W-6P	550W-4P
L		90	105

电机功率	Motor Power	450W-6P	550W-4P
L		105	105

技术参数 Technical Data

MTK 12-9I 550w-6P

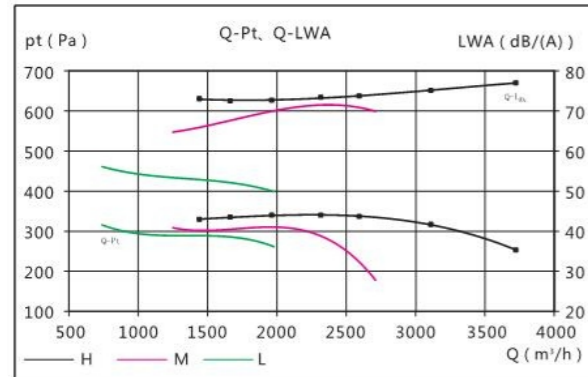

Type: MTK12-9I	Pn : 550W-6P		U : 220V				
	In : 4.7A		F : 50Hz				
	IP : IP20		m : 22.4Kg				
1/1倍频(H)							
63 Hz	54.2	54.0	54.9	55.2	54.7	53.9	55.9
125 Hz	60.4	60.2	61.1	61.4	60.9	60.1	62.1
250 Hz	69.2	67.4	66.5	67.2	66.2	65.1	65.0
500 Hz	64.3	64.0	64.3	65.2	66.0	68.1	69.2
1K Hz	66.2	66.4	66.9	67.5	68.0	69.6	71.3
2K Hz	63.3	63.7	64.5	65.4	66.2	67.9	70.2
4K Hz	62.0	62.7	63.5	64.4	65.3	67.8	70.6
8K Hz	52.2	52.6	53.1	53.7	54.6	57.0	61.9
Lwa dB(A)	73.0	72.5	72.7	73.4	73.7	75.1	77.0

MTK 12-9I 750w-6P

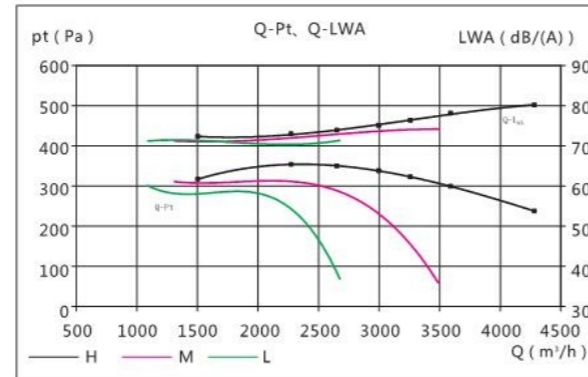

Type: MTK12-9I	Pn : 750W-6P		U : 220V				
	In : 5.4A		F : 50Hz				
	IP : IP20		m : 22.8Kg				
1/1倍频(H)							
63 Hz	55.2	55.5	55.6	55.8	59.1	55.7	55.7
125 Hz	61.4	61.7	61.8	62.0	65.3	61.9	61.9
250 Hz	65.8	65.7	66.5	66.9	67.6	70.3	69.5
500 Hz	64.9	65.2	66.1	67.6	68.8	70.4	71.6
1K Hz	66.9	67.6	68.4	69.9	71.0	73.1	75.7
2K Hz	63.4	64.8	65.8	67.1	68.3	70.3	73.0
4K Hz	61.9	63.8	65.1	66.6	67.9	69.6	72.7
8K Hz	52.2	54.6	56.3	58.3	59.8	61.5	64.9
Lwa dB(A)	72.3	73.0	73.9	75.1	76.3	78.1	80.2

技术参数 Technical Data

MTK 12-12I 550w-6P

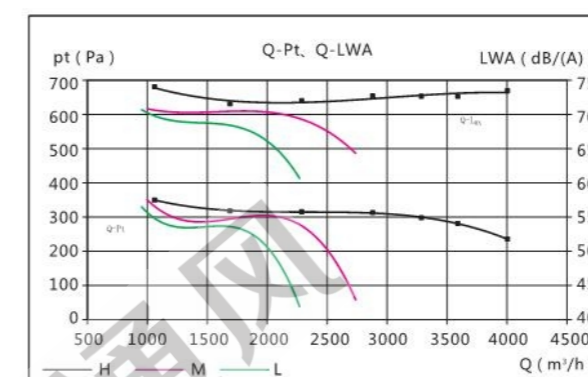

Type: MTK12-12I	Pn : 550W-6P		U : 220V				
	In : 4.7A		F : 50Hz				
	IP : IP20		m : 24Kg				
1/1倍频(H)							
63 Hz	54.6	55.3	55.0	55.1	55.2	55.2	54.5
125 Hz	60.8	61.5	61.2	61.3	61.4	61.4	60.7
250 Hz	71.1	65.2	66.9	66.2	66.2	63.6	63.5
500 Hz	65.2	64.3	63.8	64.7	65.2	65.7	66.4
1K Hz	65.7	65.4	65.4	66.4	66.4	66.7	67.5
2K Hz	63.9	63.0	63.5	65.2	64.8	65.5	66.8
4K Hz	62.2	61.0	61.8	63.5	63.1	63.9	65.4
8K Hz	53.5	52.1	52.5	53.8	54.2	55.1	57.8
Lwa dB(A)	74.0	71.6	72.0	72.7	72.7	72.6	73.5

MTK 12-12I 750w-6P

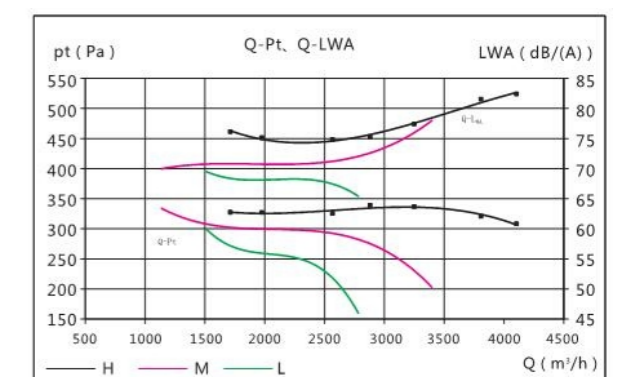

Type: MTK12-12I	Pn : 750W-6P		U : 220V				
	In : 5.4A		F : 50Hz				
	IP : IP20		m : 24.8Kg				
1/1倍频(H)							
63 Hz	56.4	55.7	55.0	55.8	57.3	56.1	57.5
125 Hz	62.6	61.9	61.2	62.0	63.5	62.3	63.7
250 Hz	68.1	66.8	71.7	72.5	75.2	81.2	82.0
500 Hz	68.0	67.3	65.2	65.3	67.2	64.2	67.0
1K Hz	69.0	68.3	66.2	66.4	67.8	63.6	65.1
2K Hz	69.6	68.5	65.5	65.6	66.8	61.8	63.2
4K Hz	68.5	67.3	64.3	64.3	65.2	59.6	61.3
8K Hz	63.5	62.4	56.6	55.7	56.9	51.6	53.7
Lwa dB(A)	76.1	75.1	74.8	75.3	77.4	81.5	82.4

外形及安装尺寸 Overall size

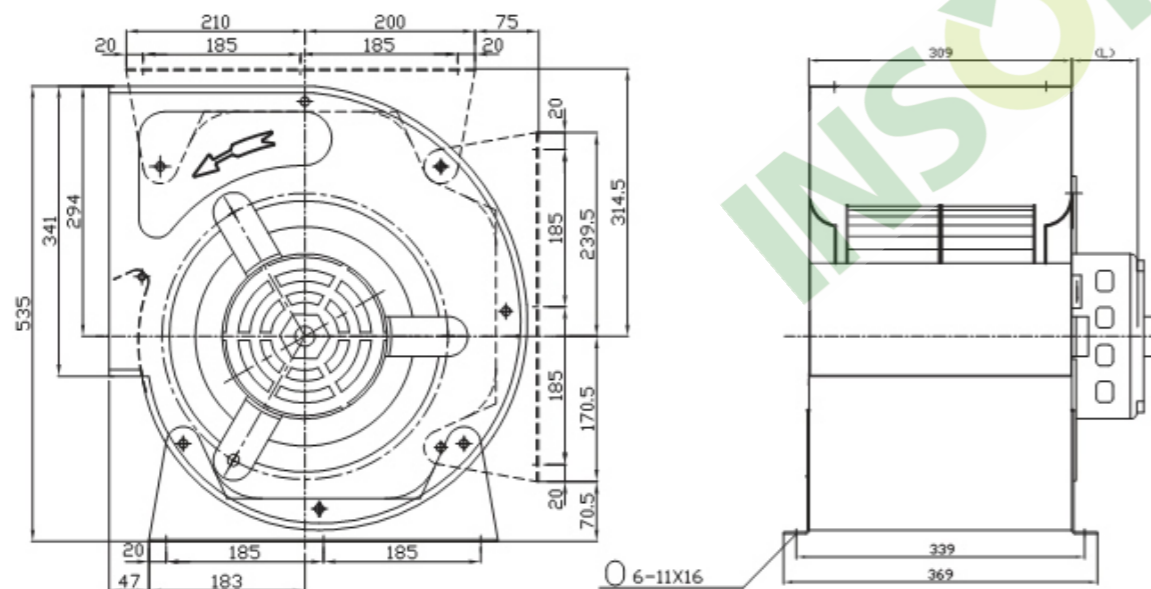

电机功率	Motor Power	550W-6P	750W-6P
L		105	125

外形及安装尺寸 Overall size

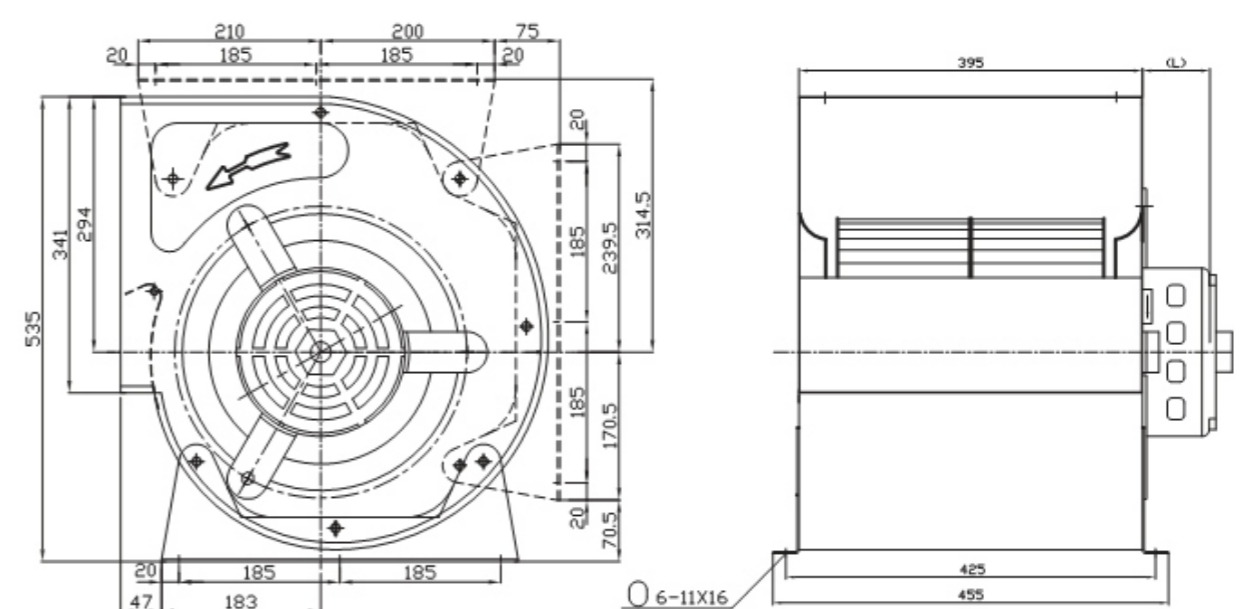

电机功率	Motor Power	550W-6P	750W-6P
L		105	125