

### ▶ BAS曲线图 BAS Curve

标准宽度

标准宽度

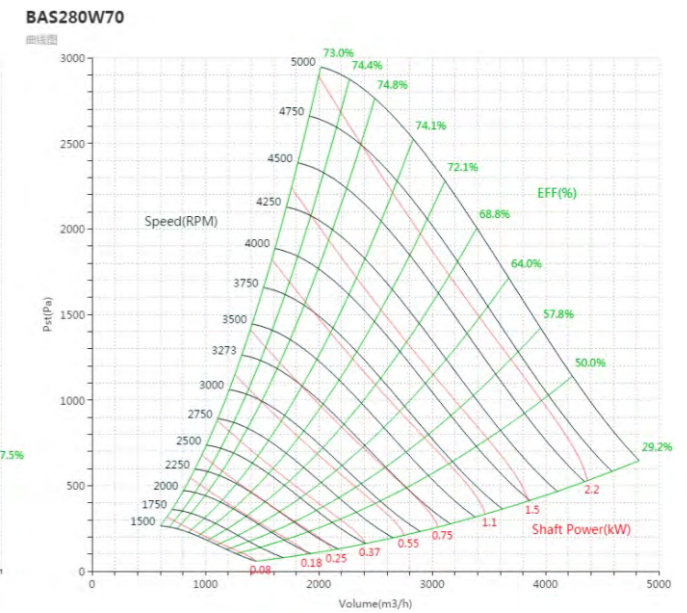
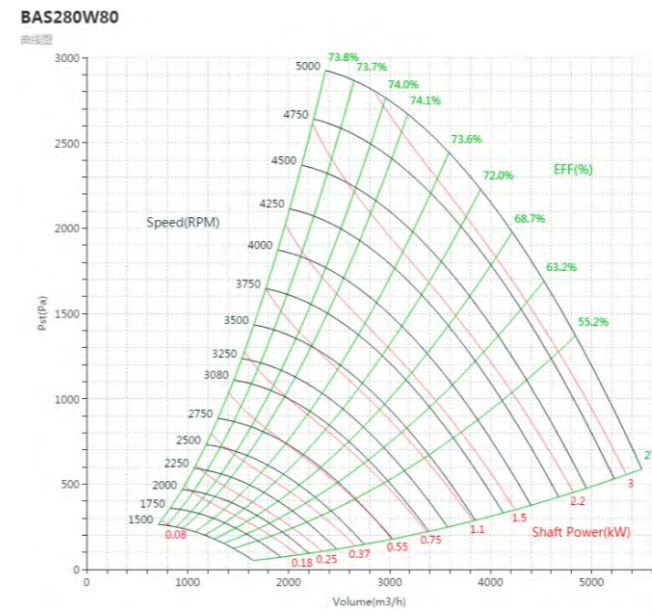
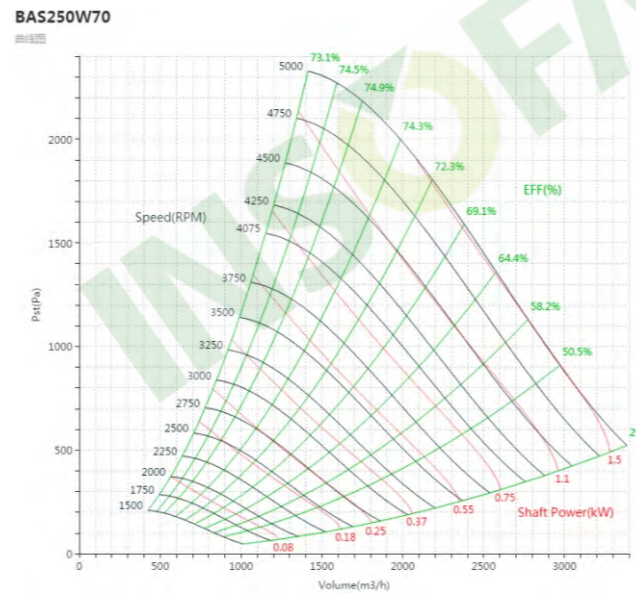
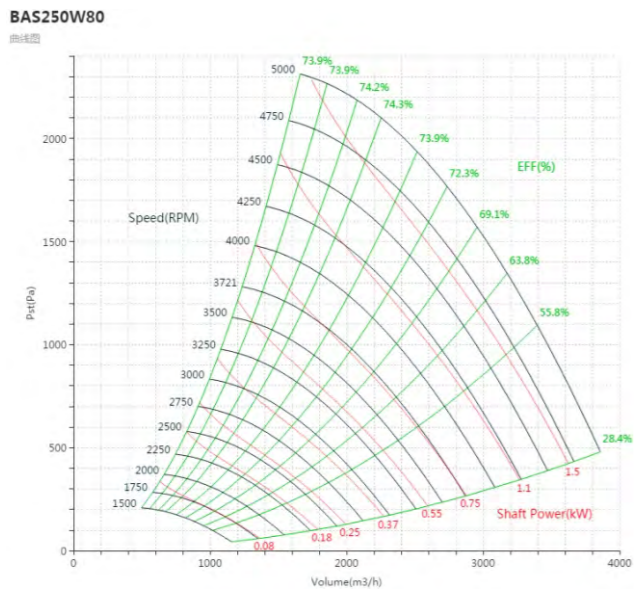
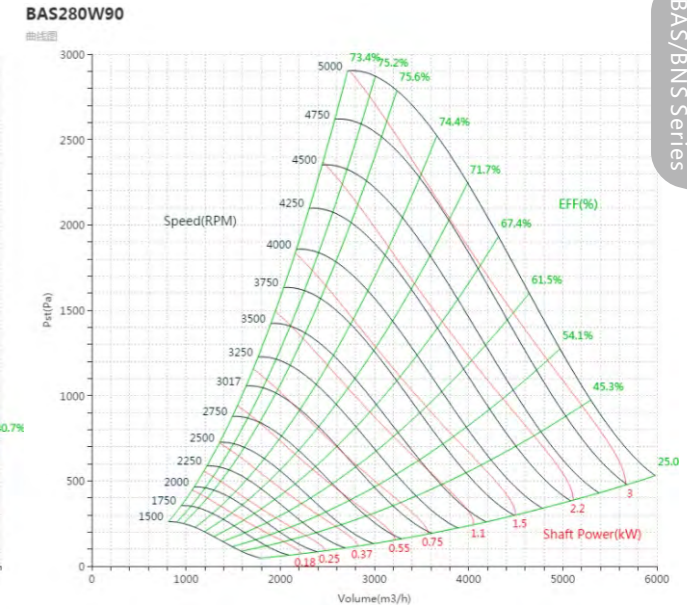
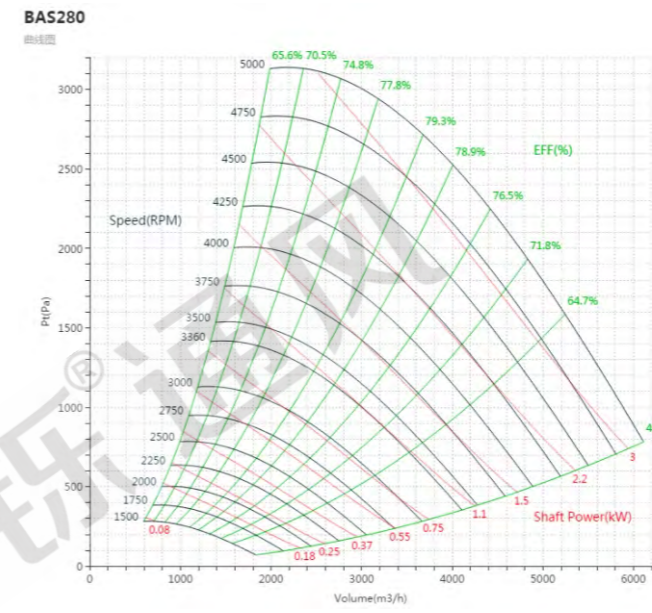
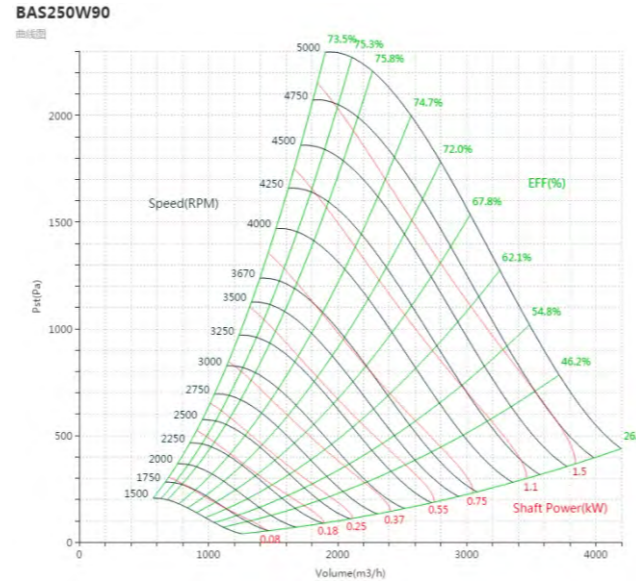
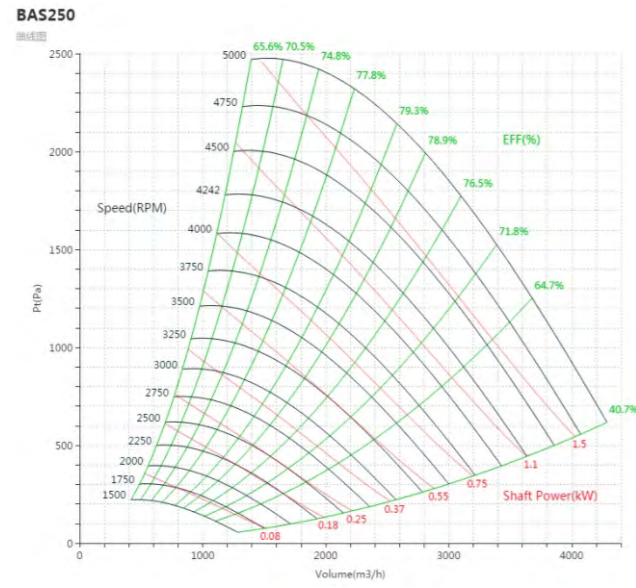

标准宽度

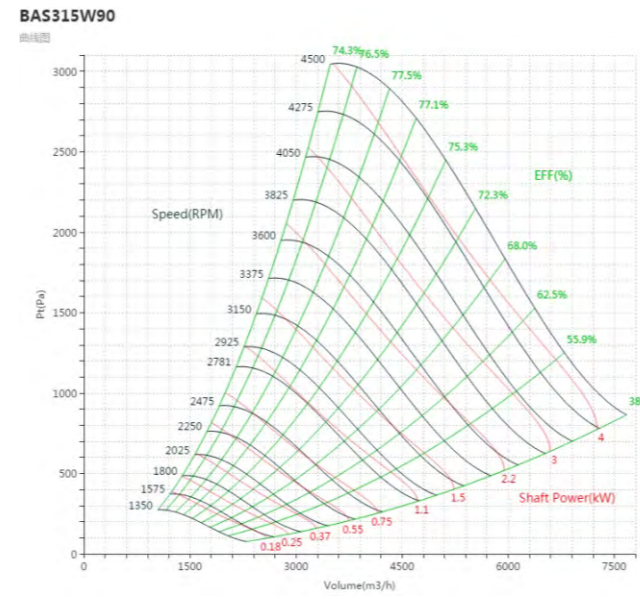
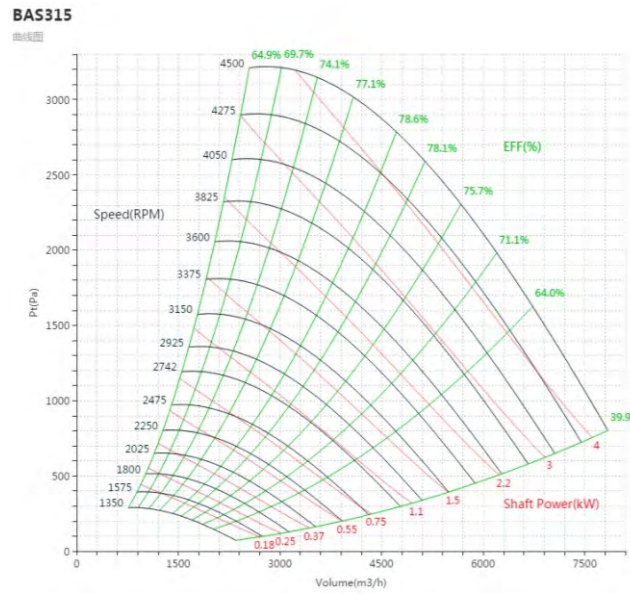

标准宽度

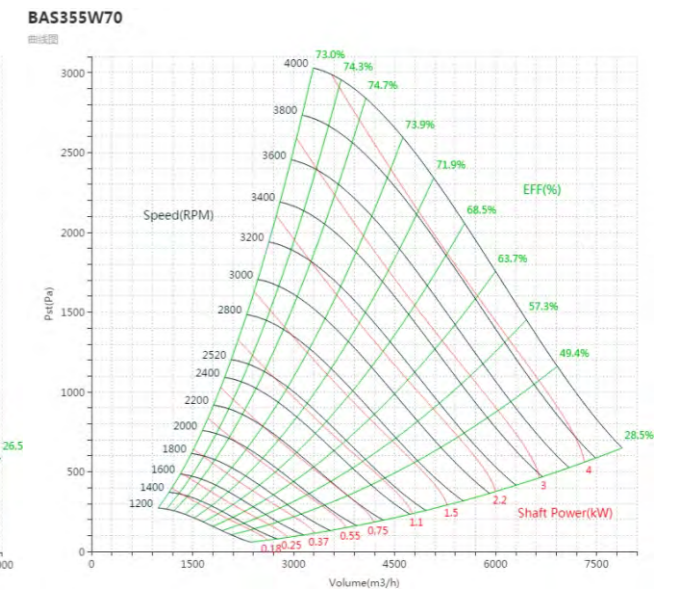
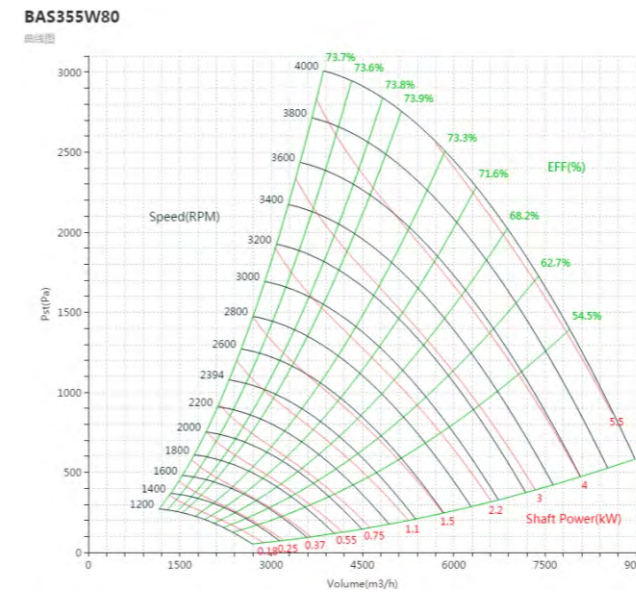
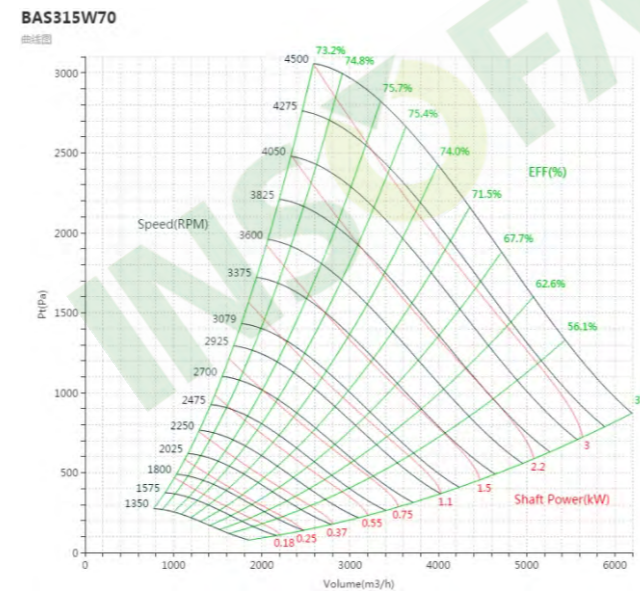
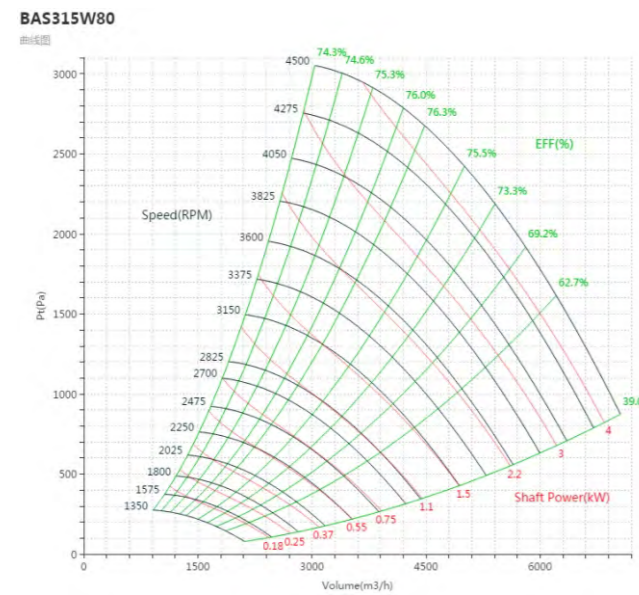
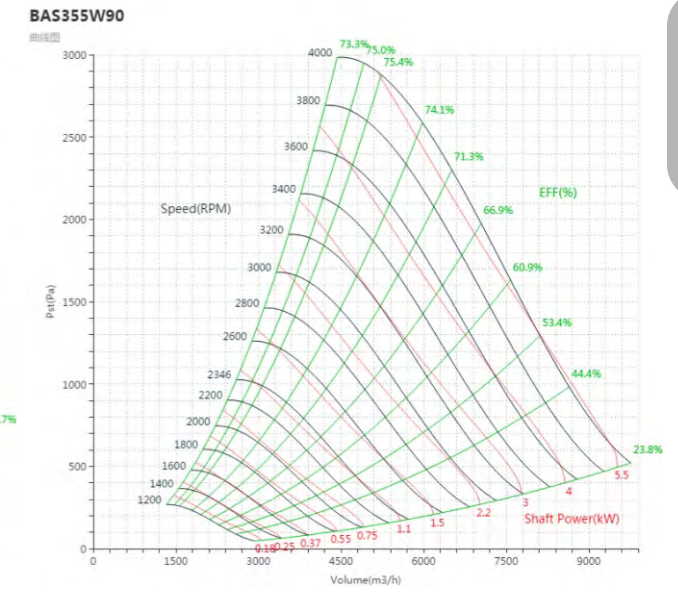
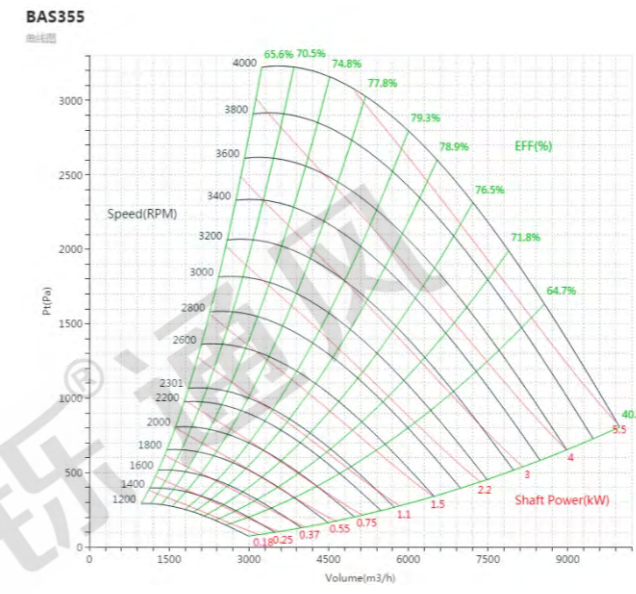

标准宽度

标准宽度

BAS400

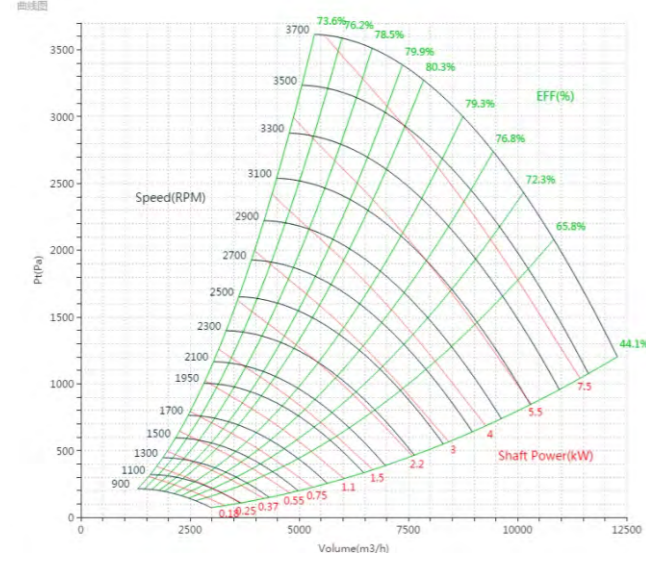

BAS400W90

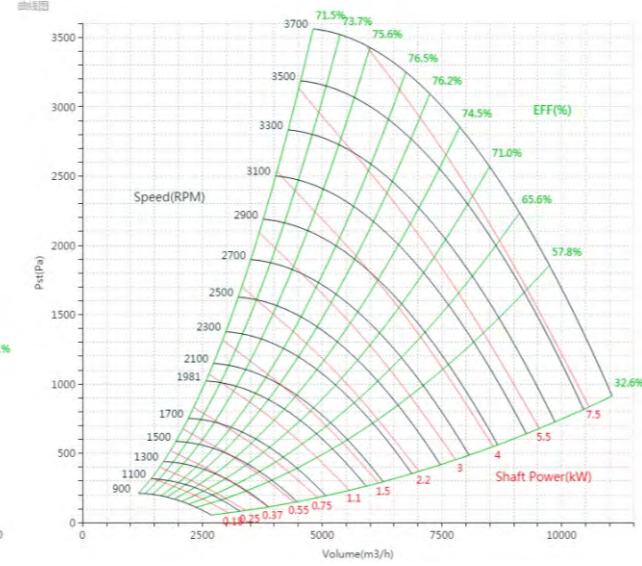

BAS450

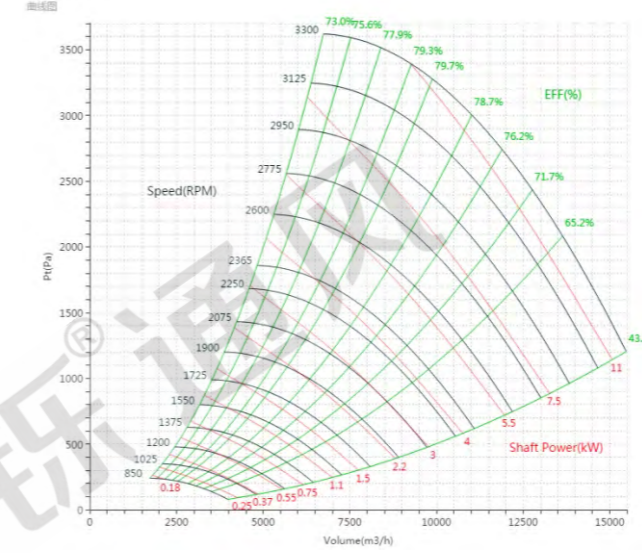

BAS450W90

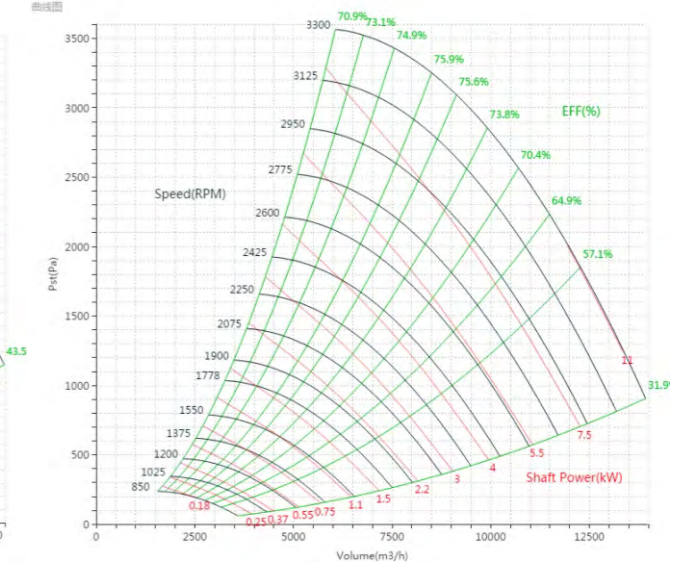

BAS400W80

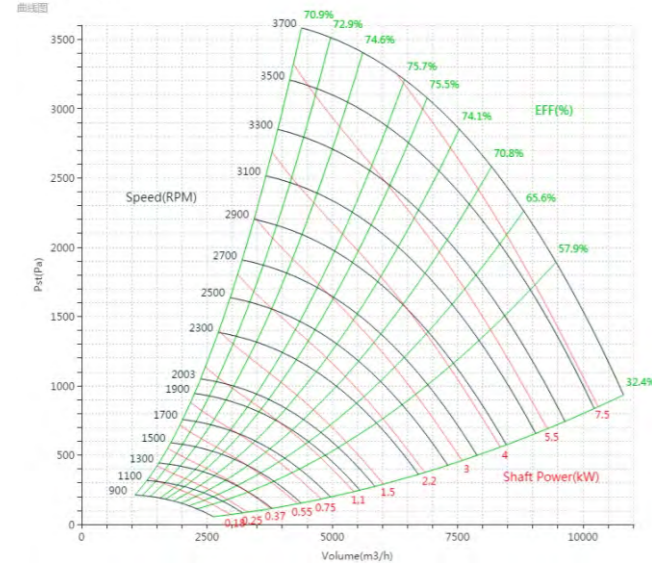

BAS400W70

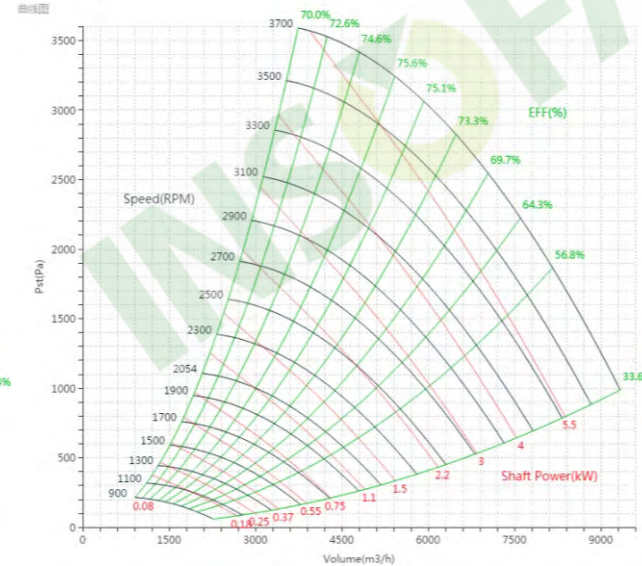

BAS450W80

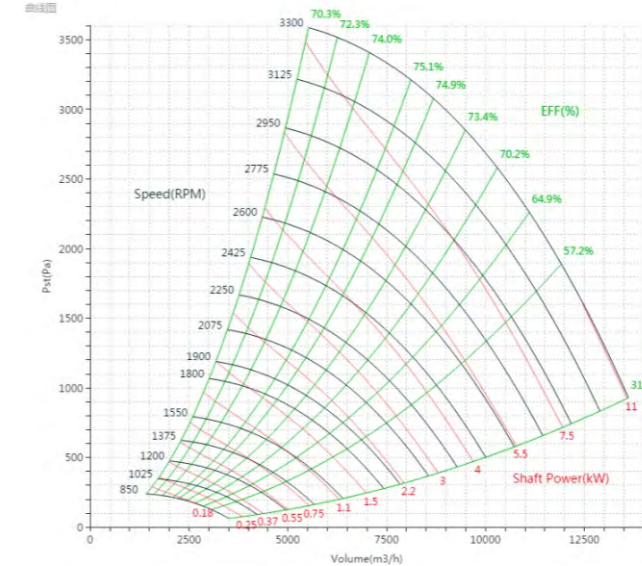

BAS450W70

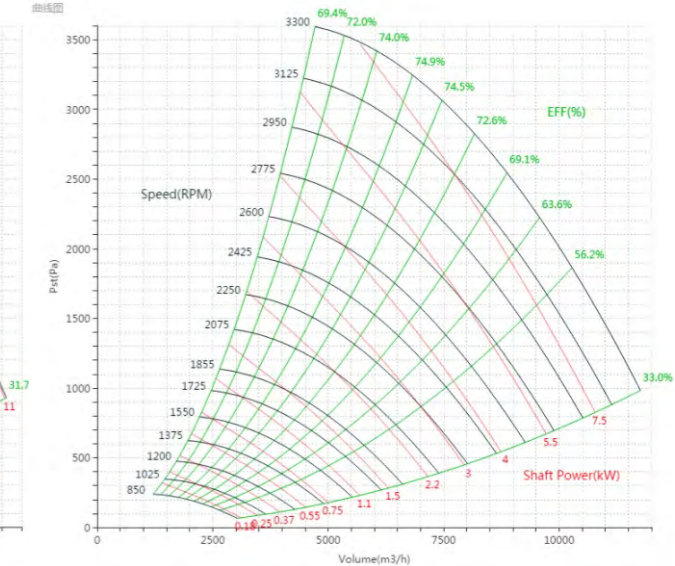

BAS/BNS Series

BAS/BNS Series

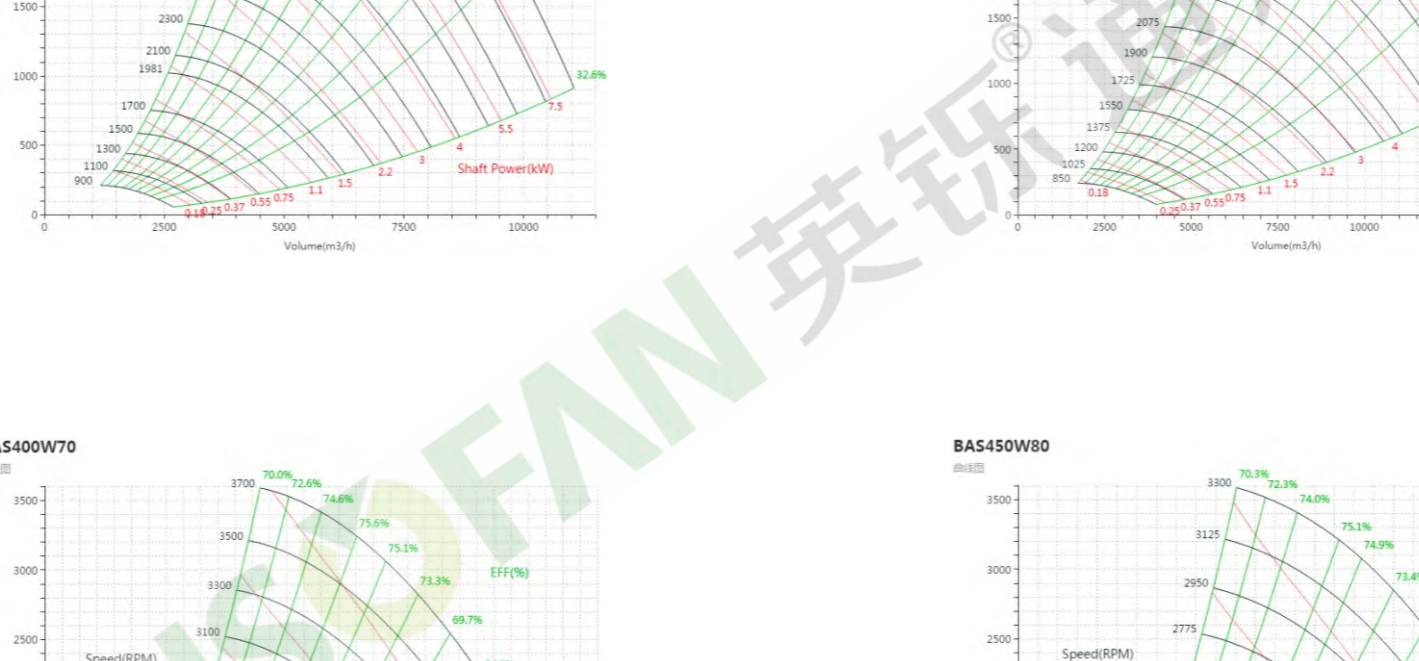

标准宽度

标准宽度

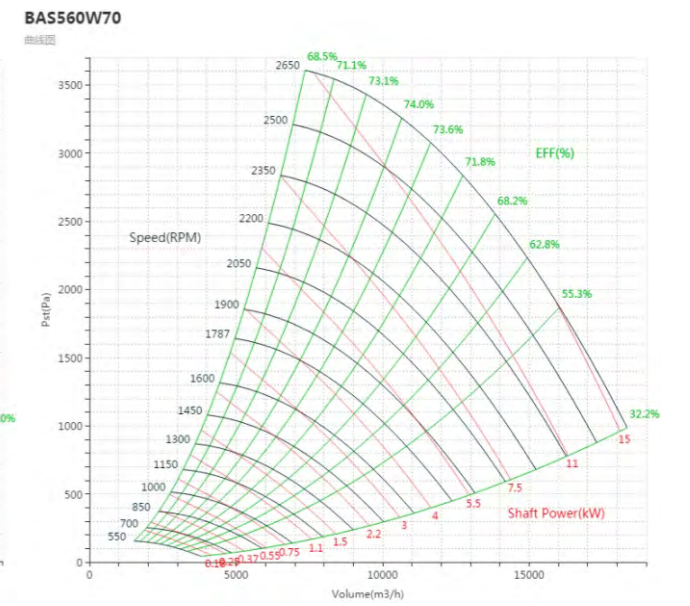
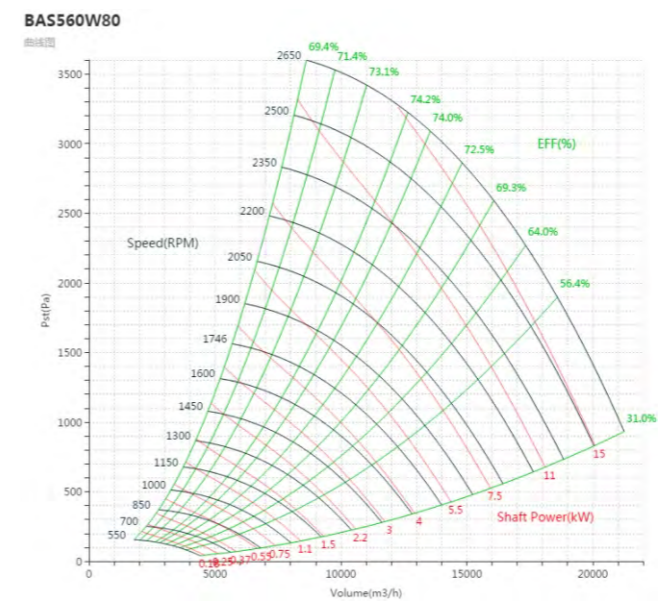
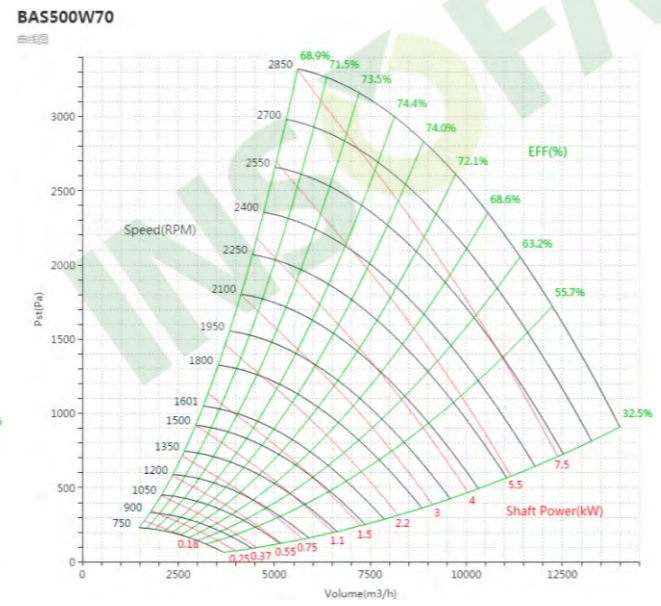
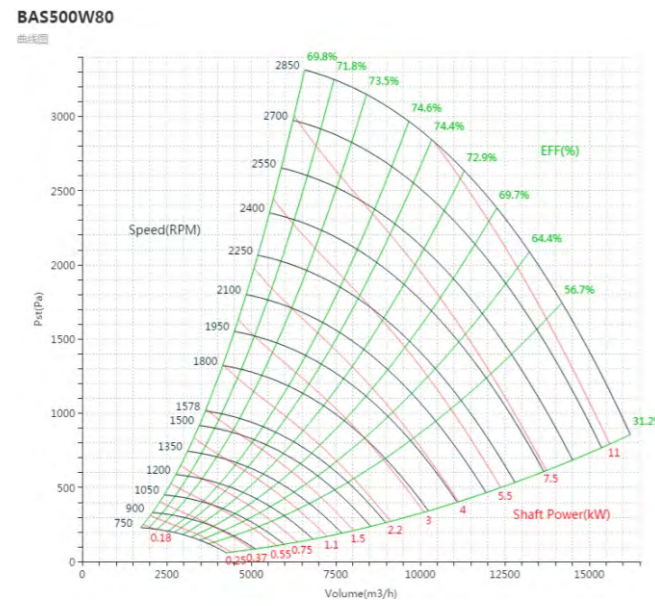
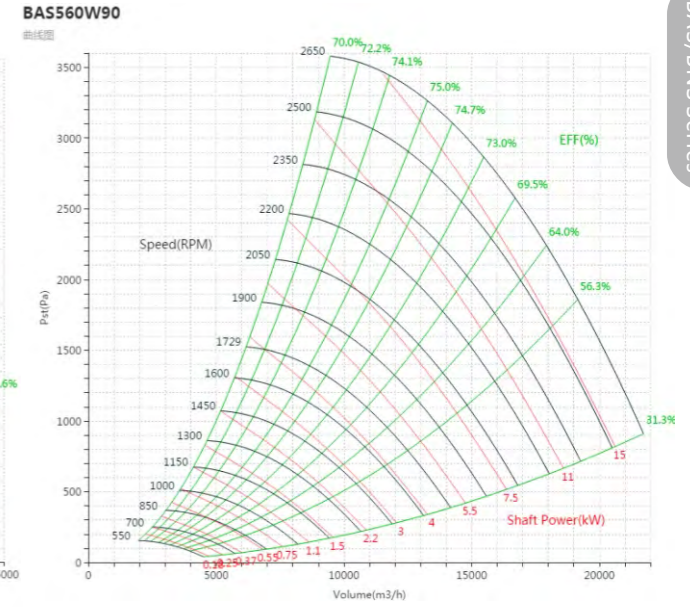
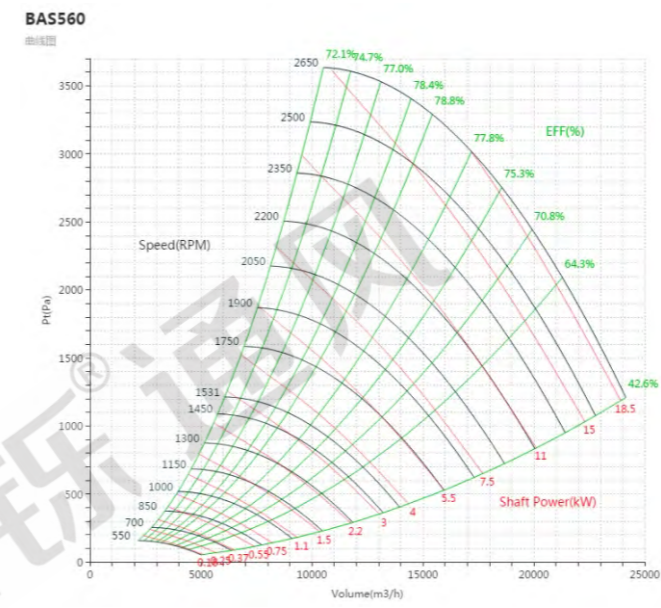
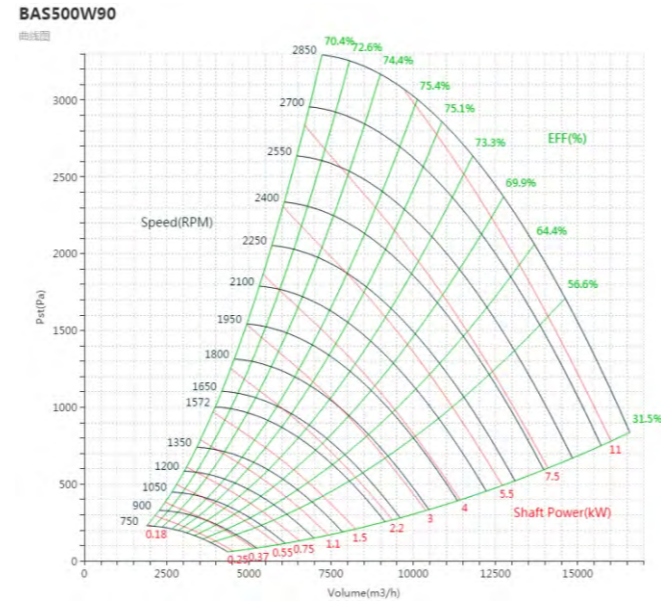
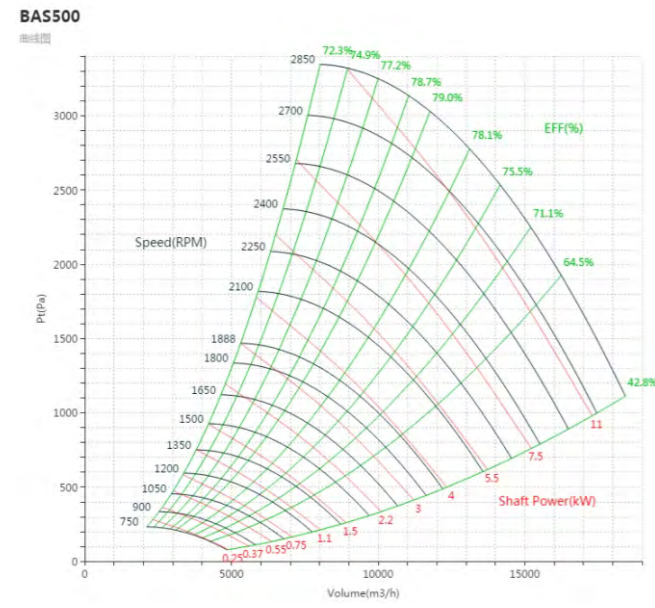

BAS/BNS Series

BAS/BNS Series

标准宽度

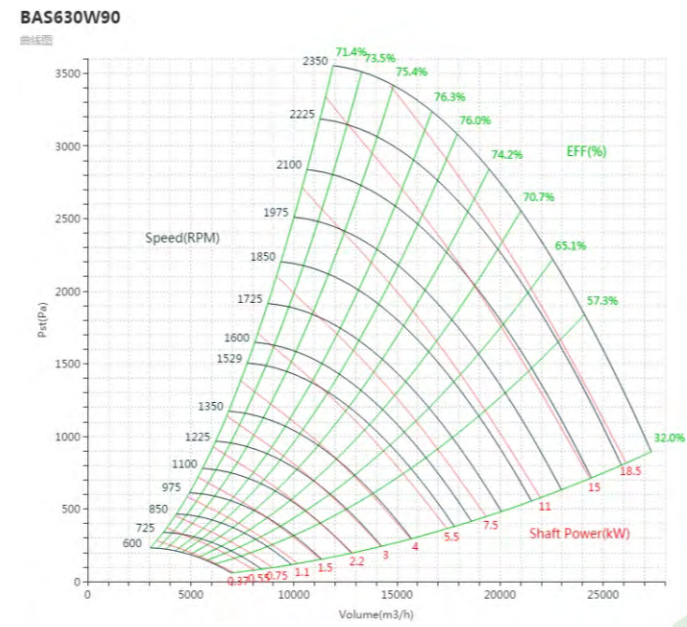
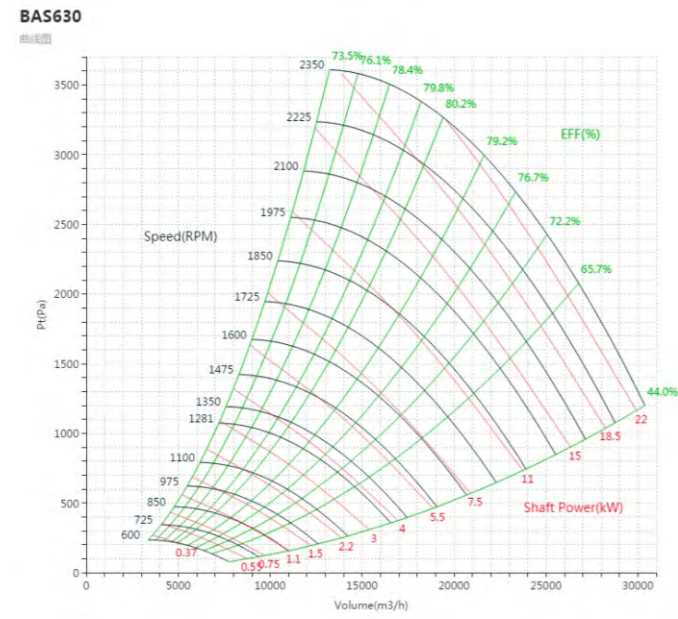

标准宽度

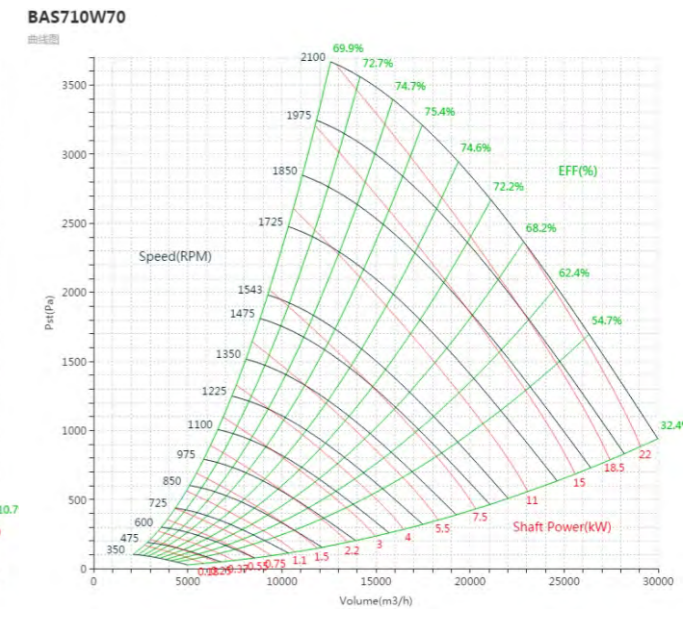
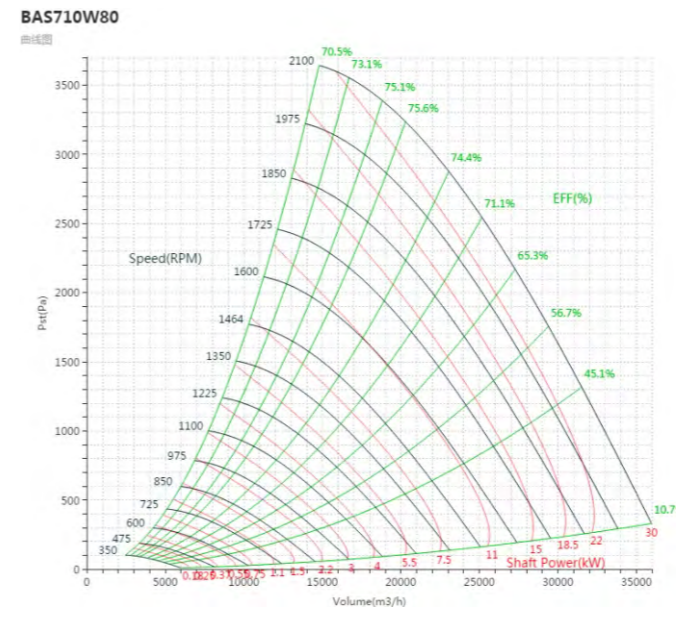
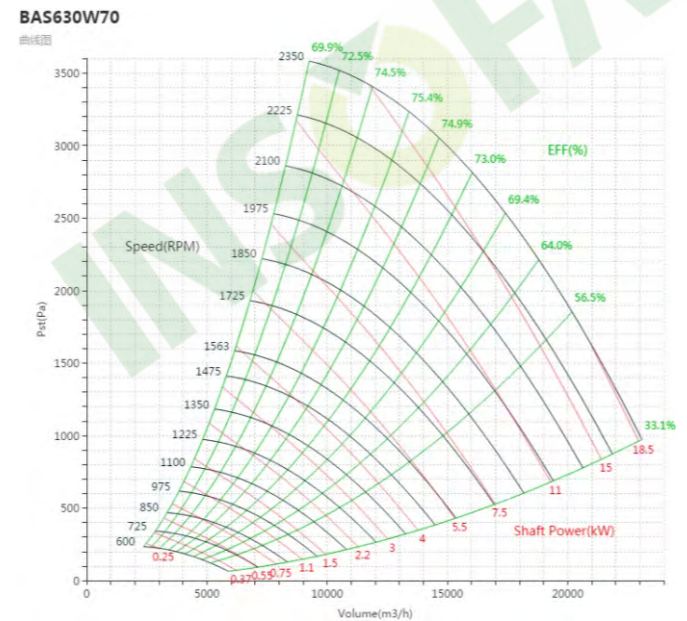
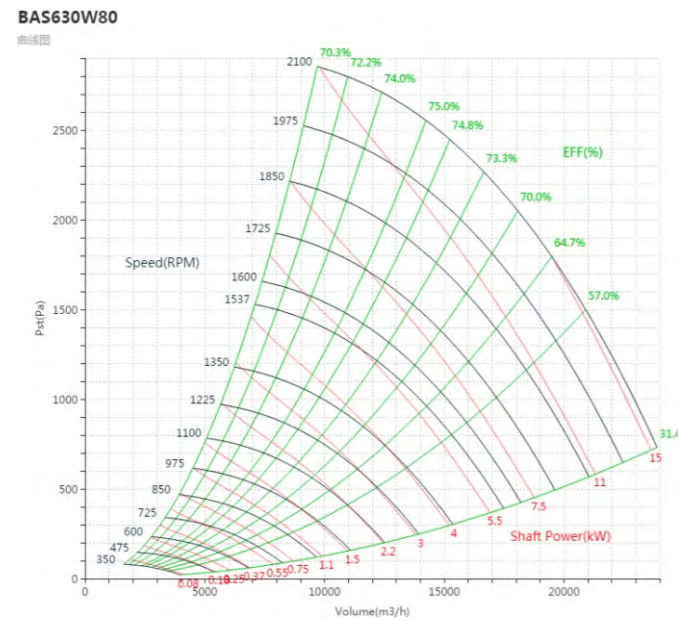
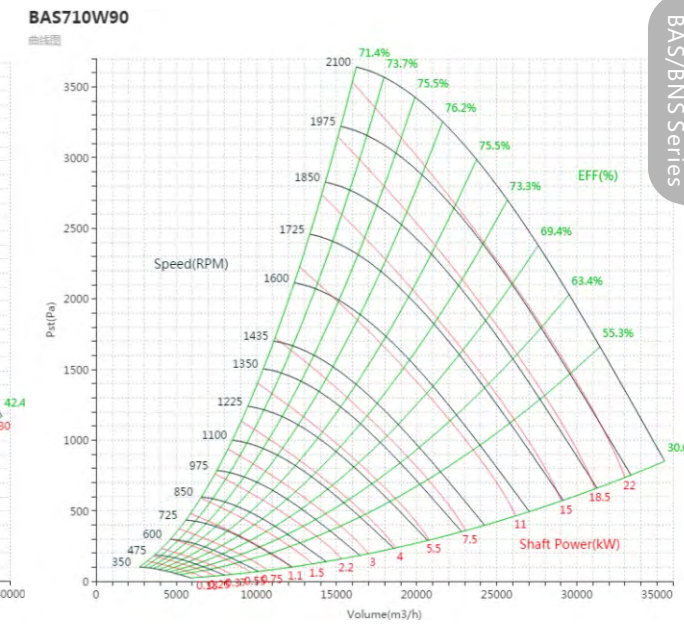
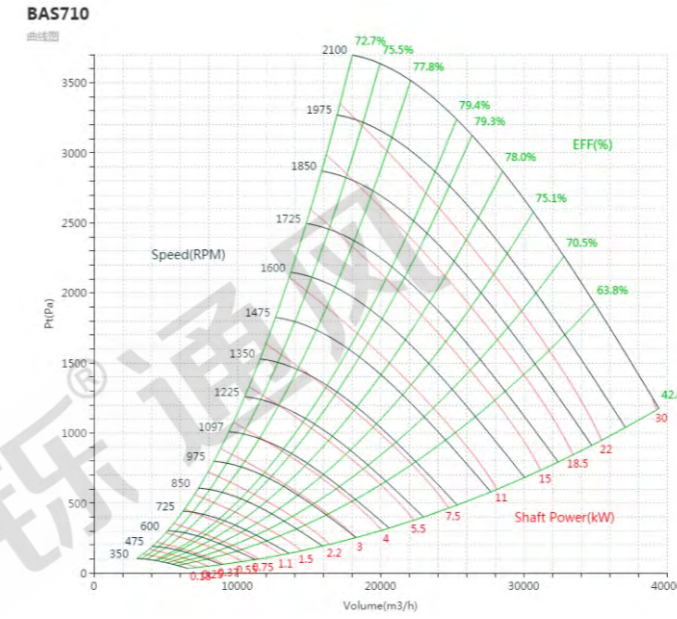

标准宽度

标准宽度

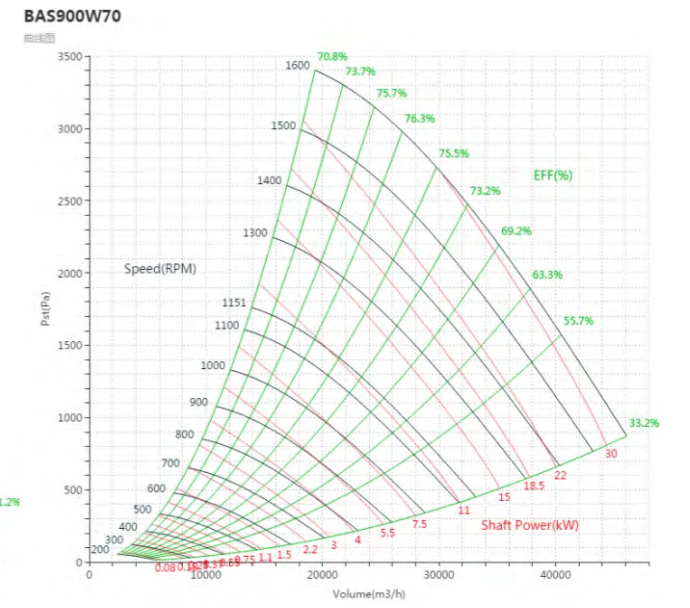
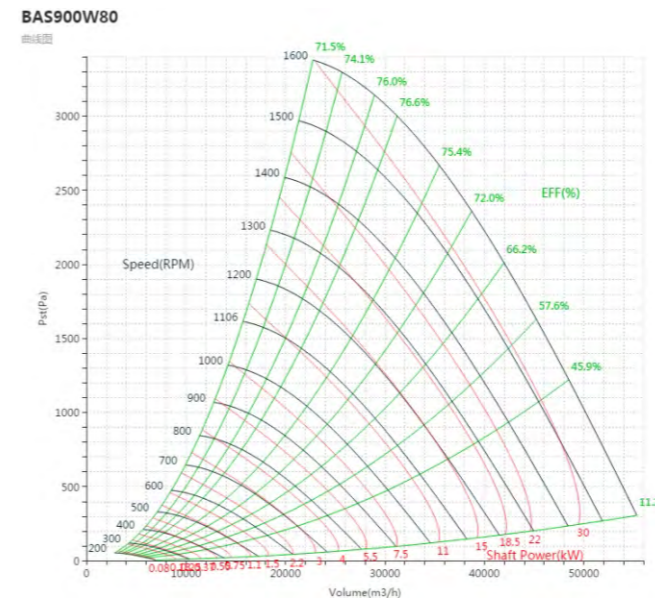
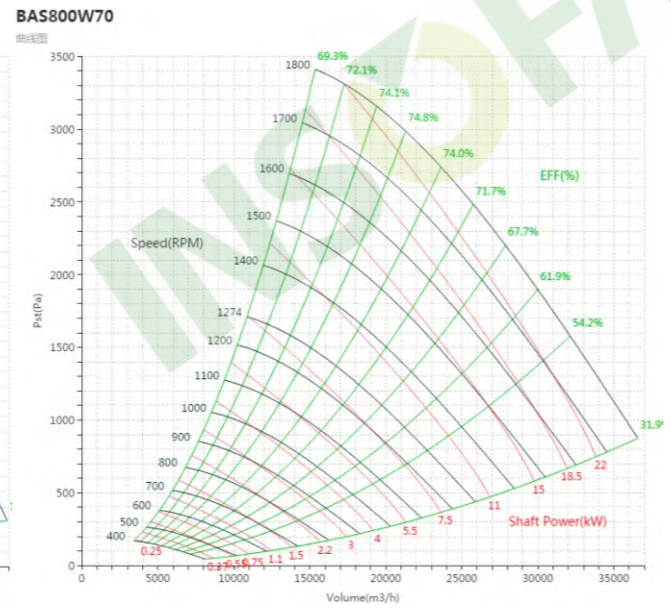
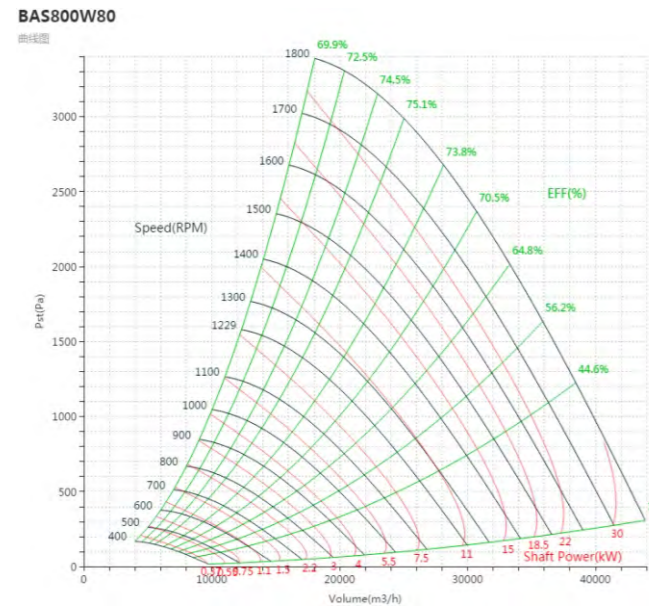
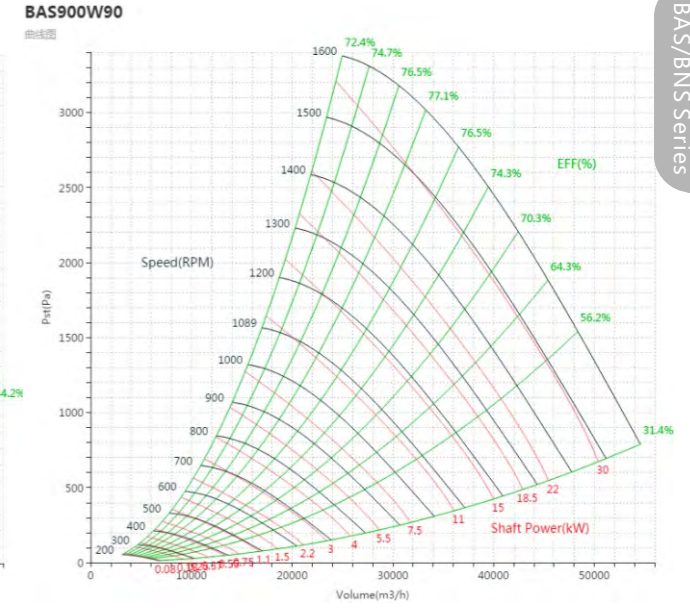
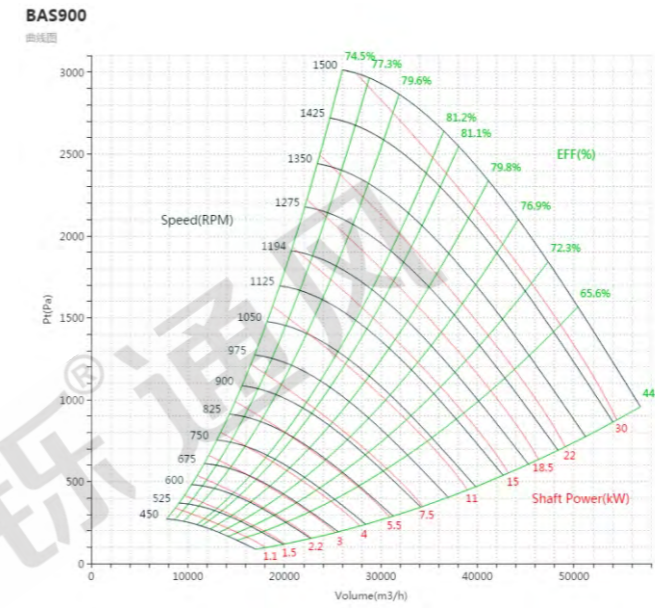
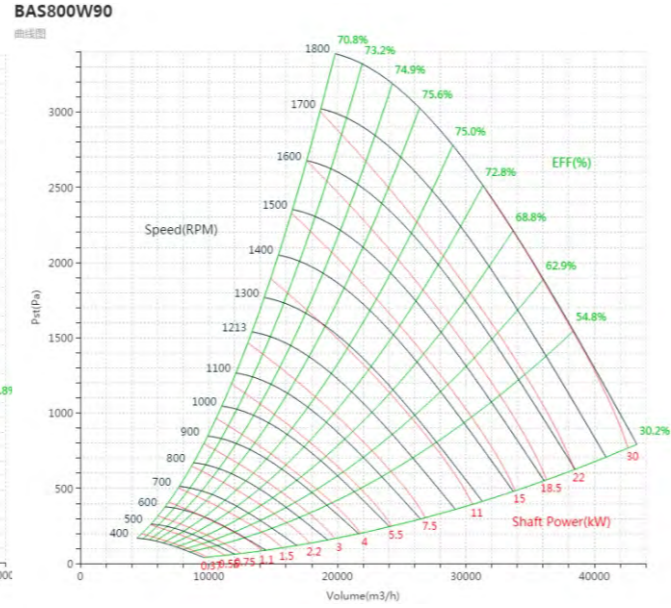
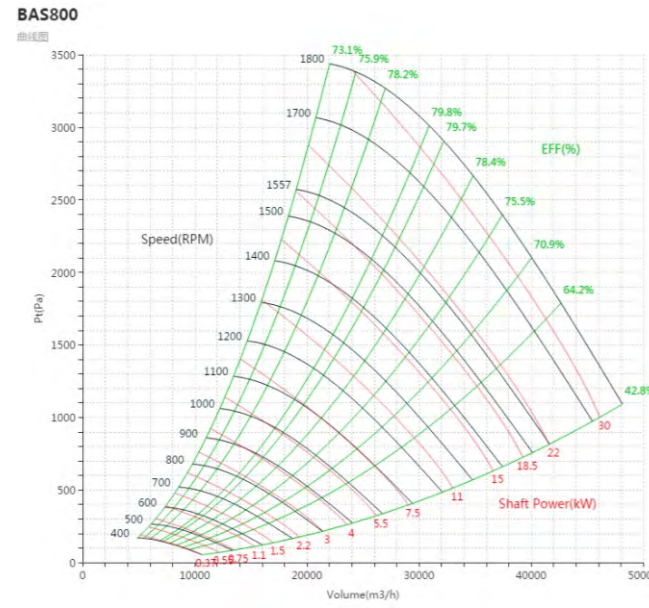

BNS曲线图 BNS Curve

标准宽度

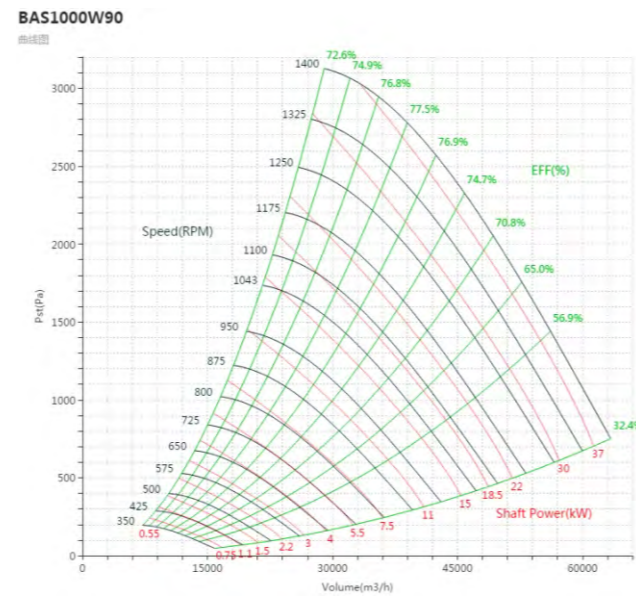
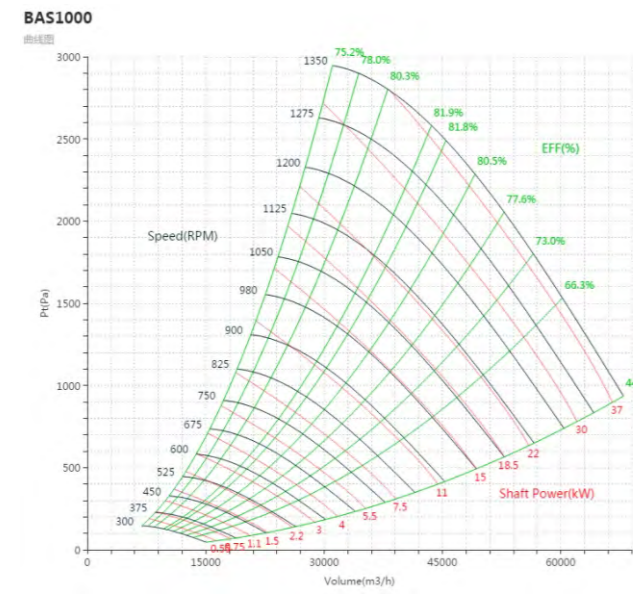

标准宽度

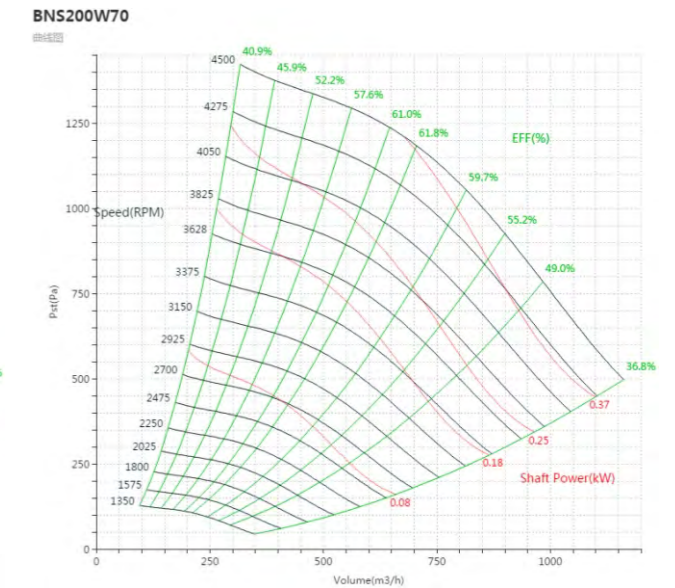
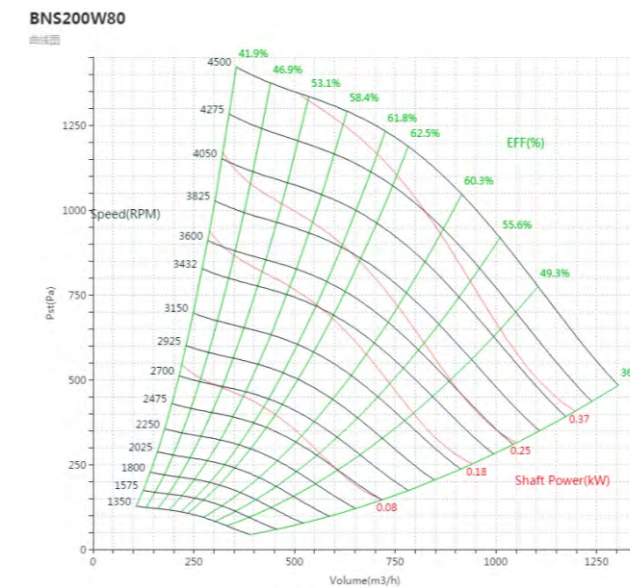
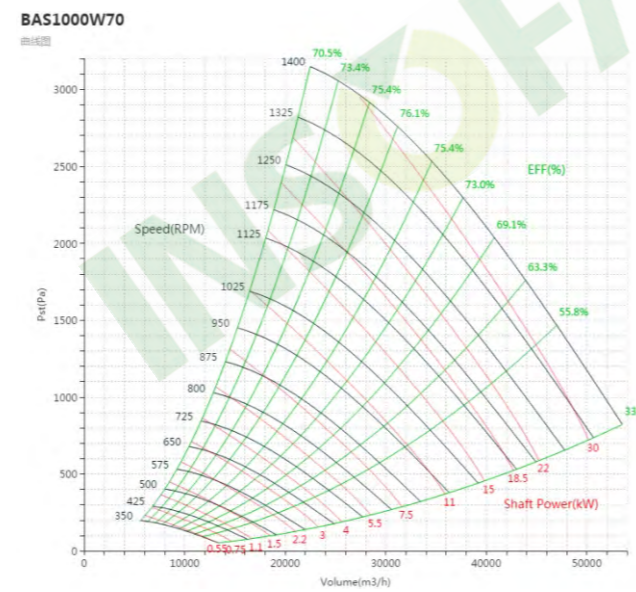
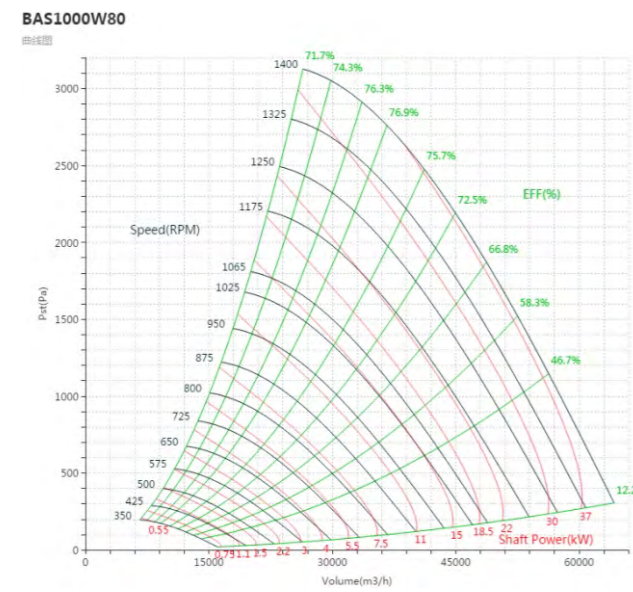
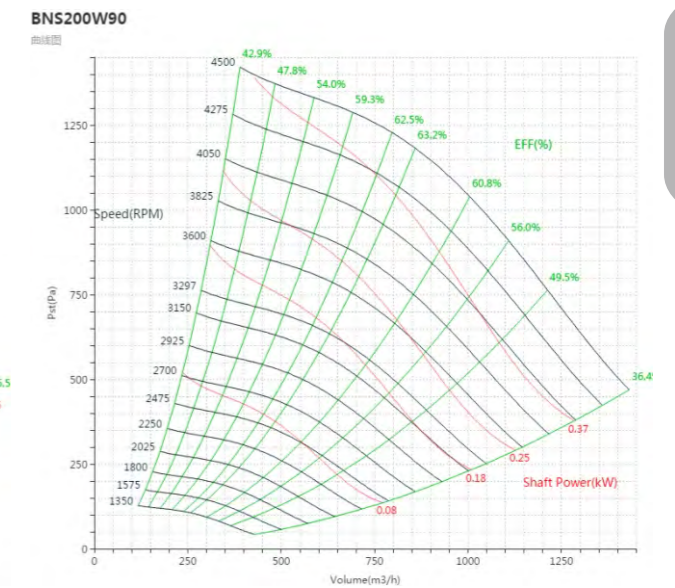
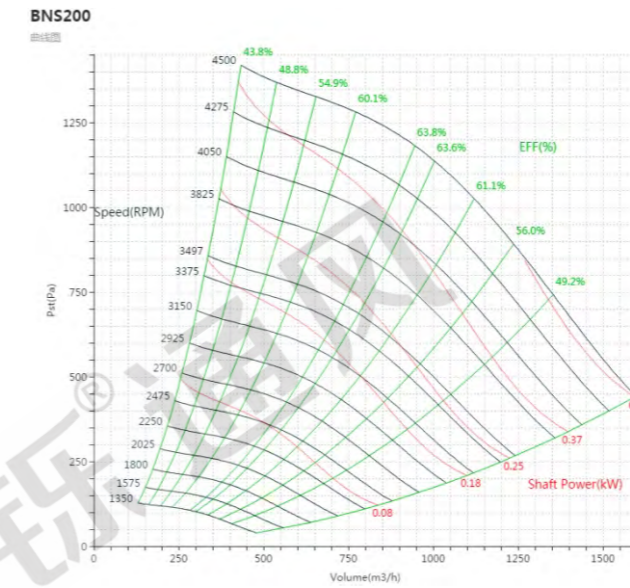

标准宽度

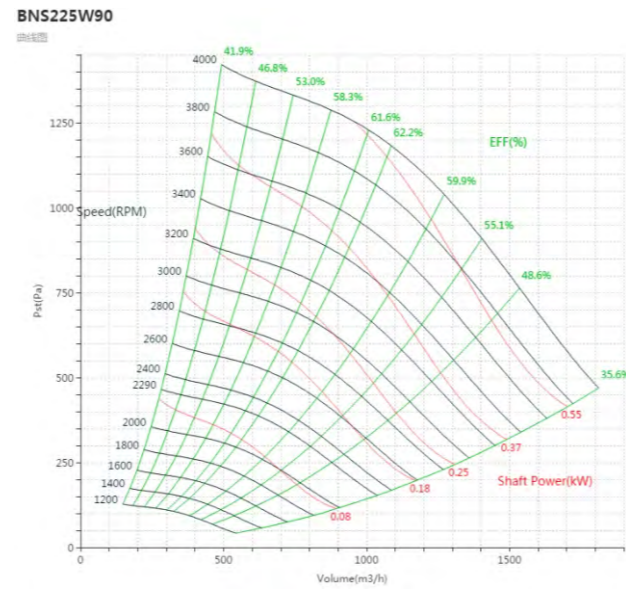
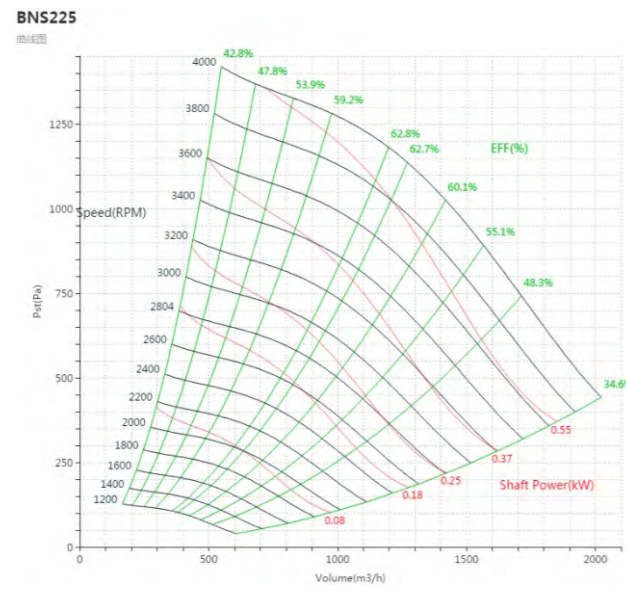

标准宽度

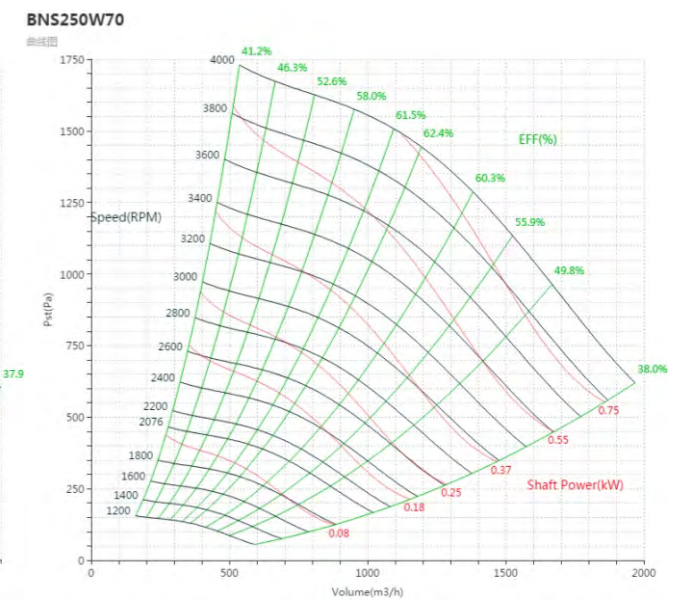
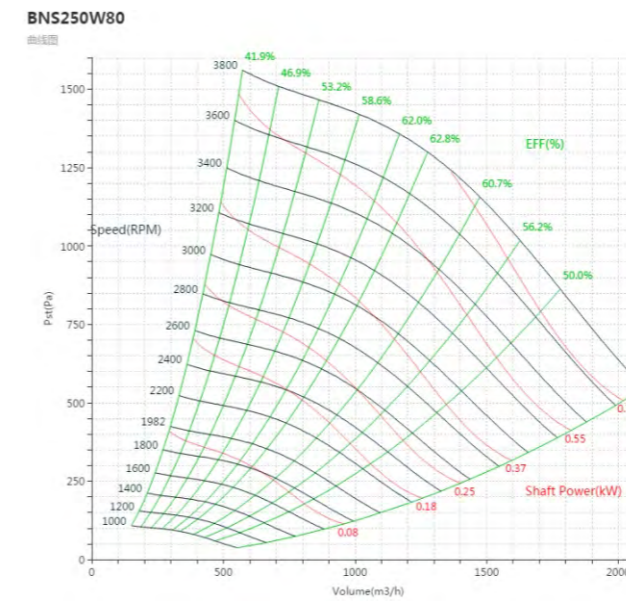
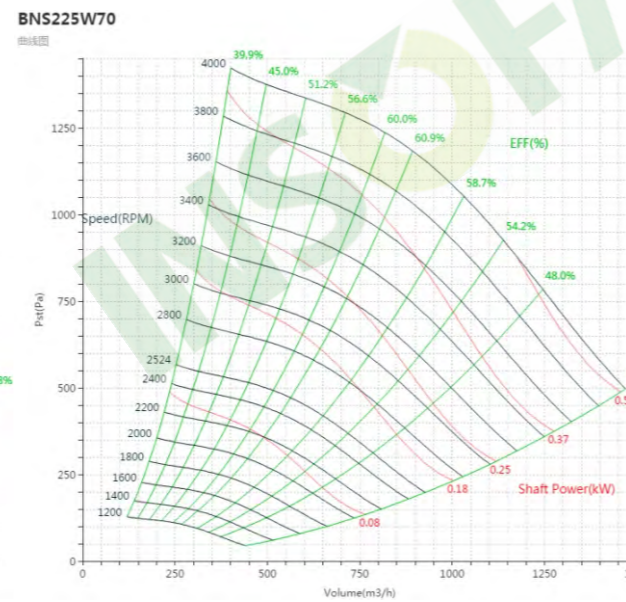
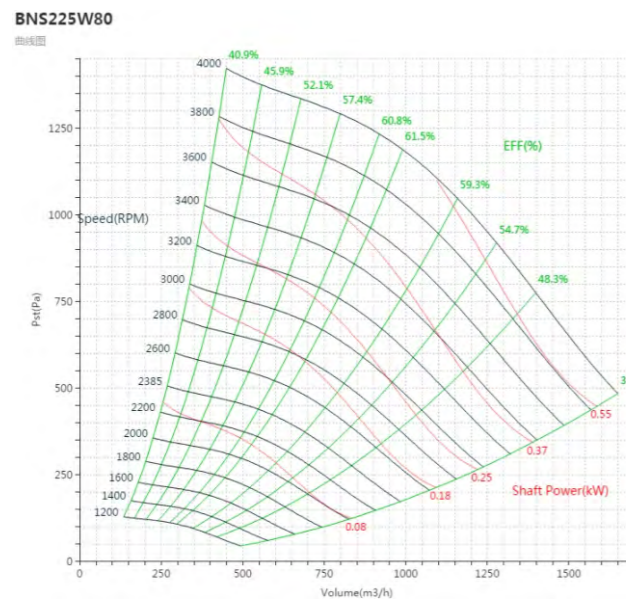
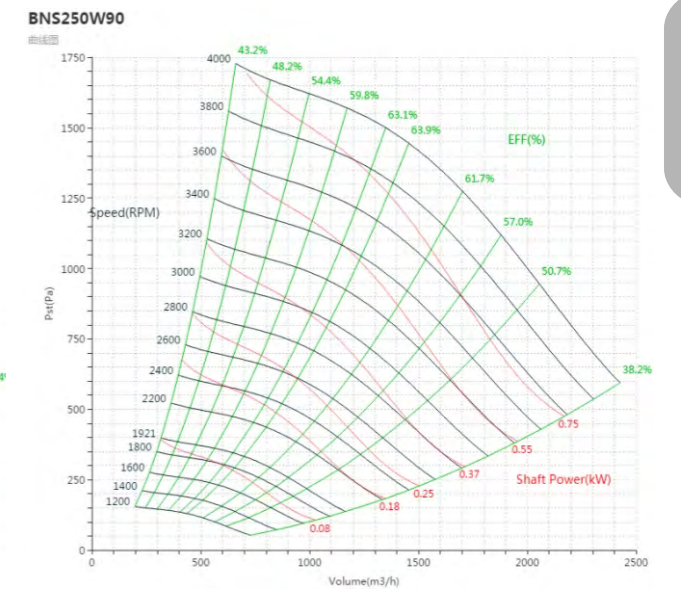
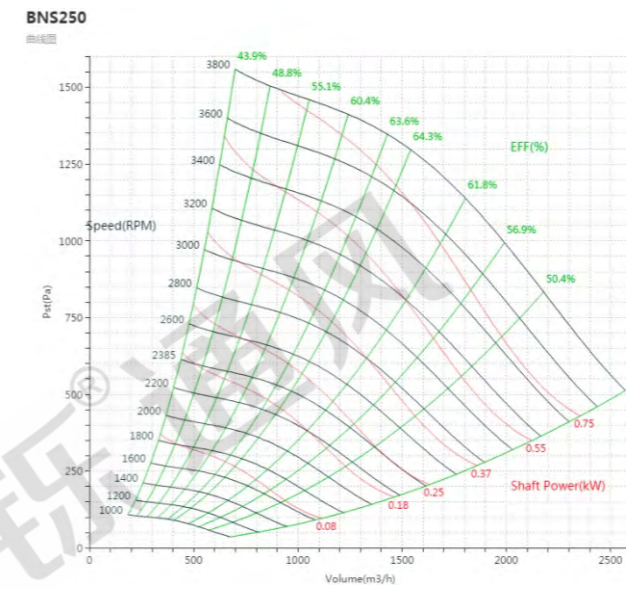

BAS/BNS Series

BAS/BNS Series

标准宽度

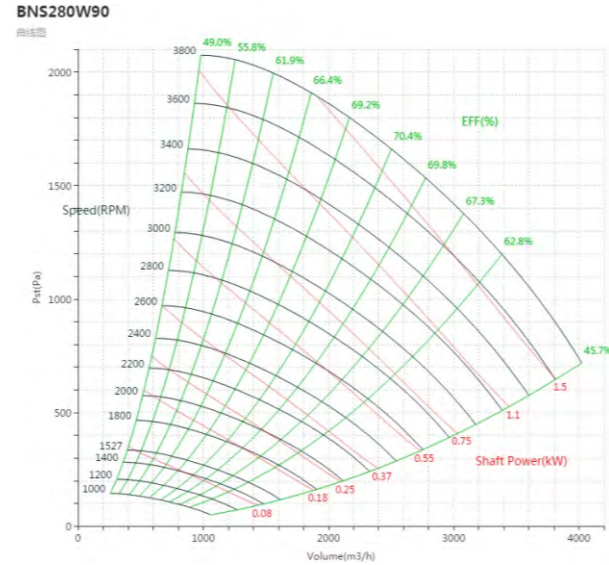
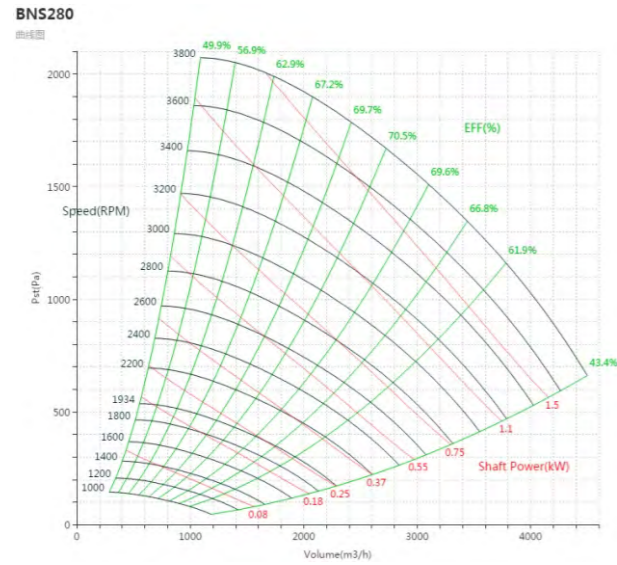

标准宽度

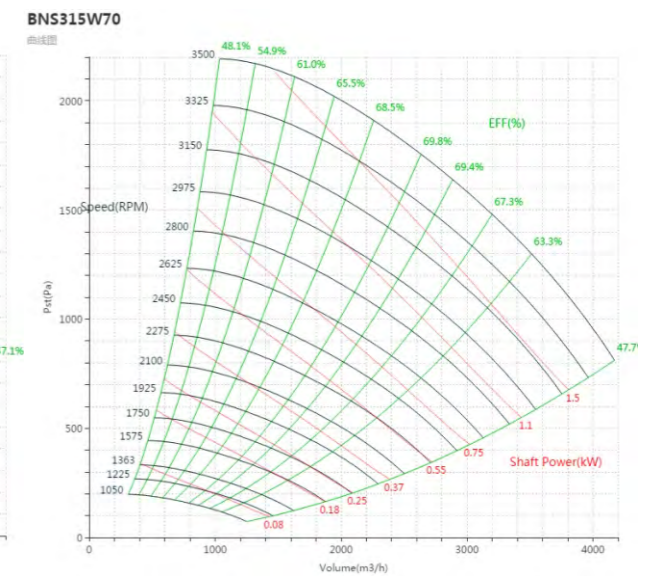
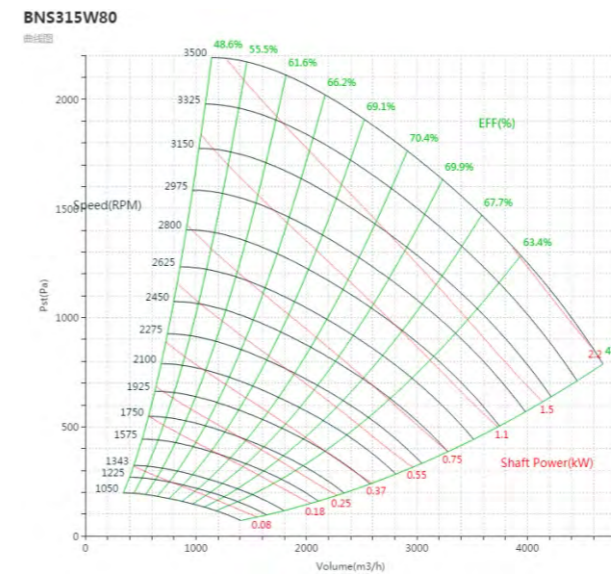
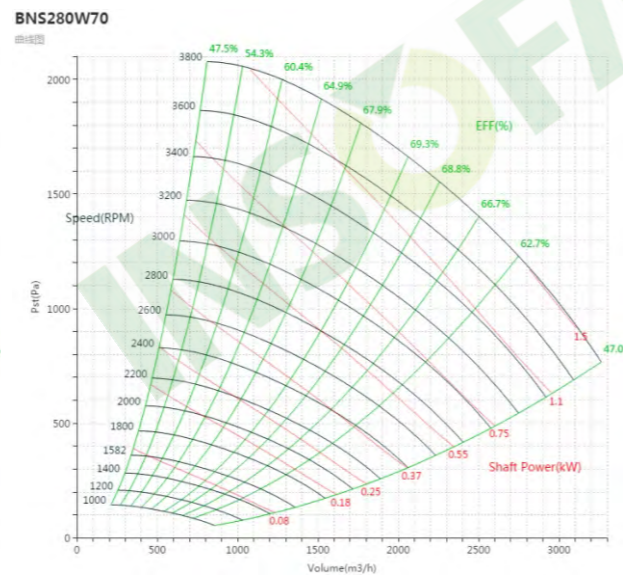
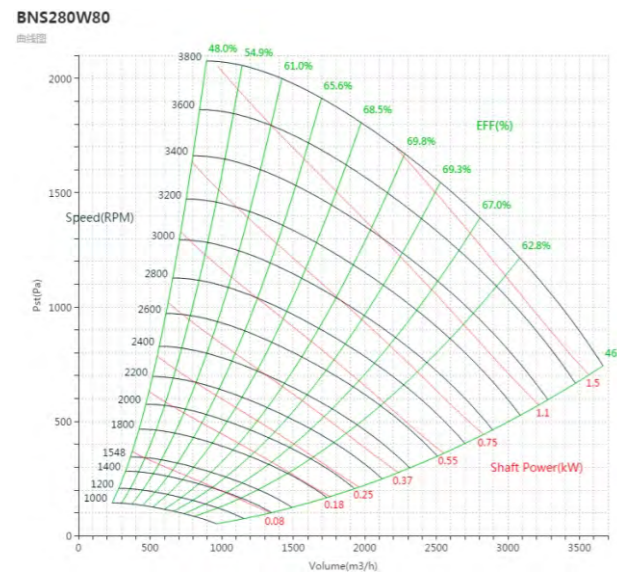
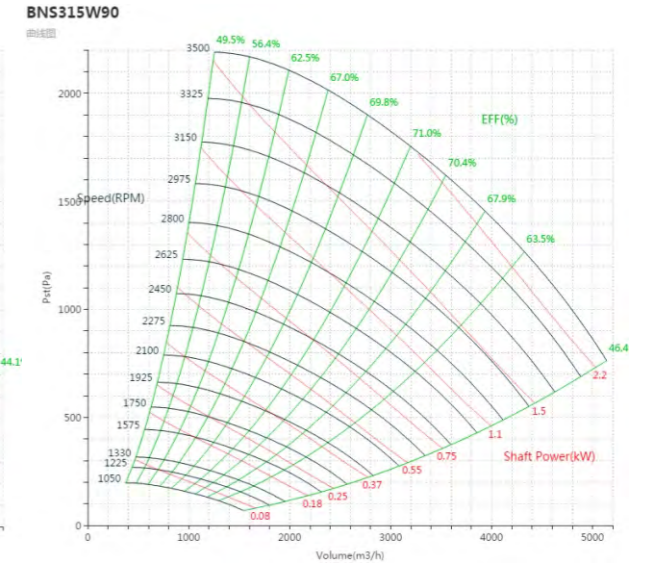

标准宽度

BNS355

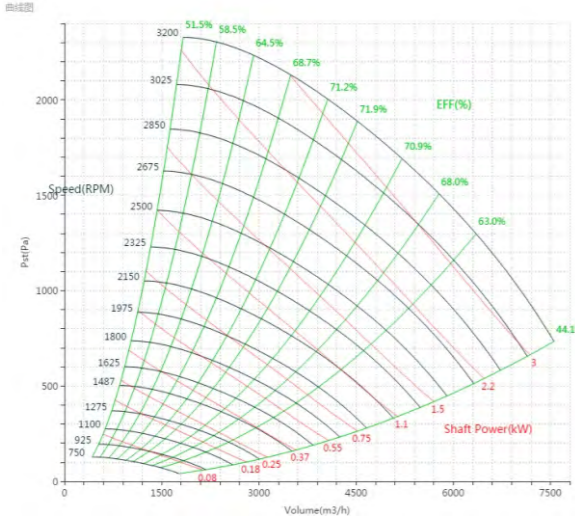

BNS355W90

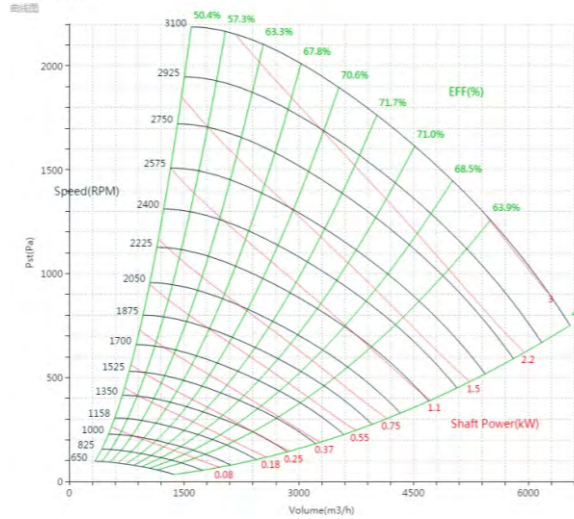

标准宽度

BNS400

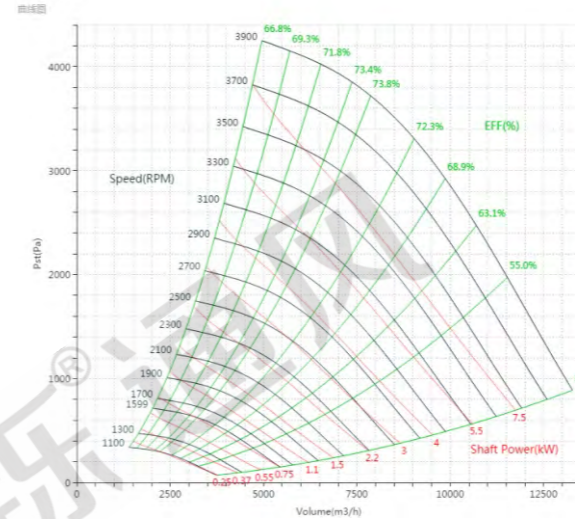

BNS400W90

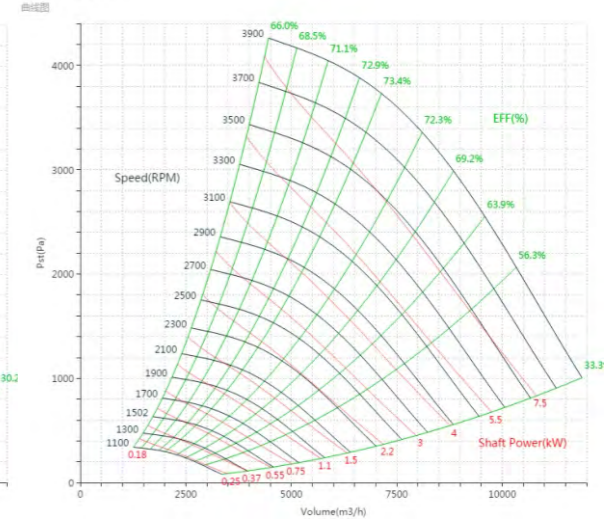

BNS355W80

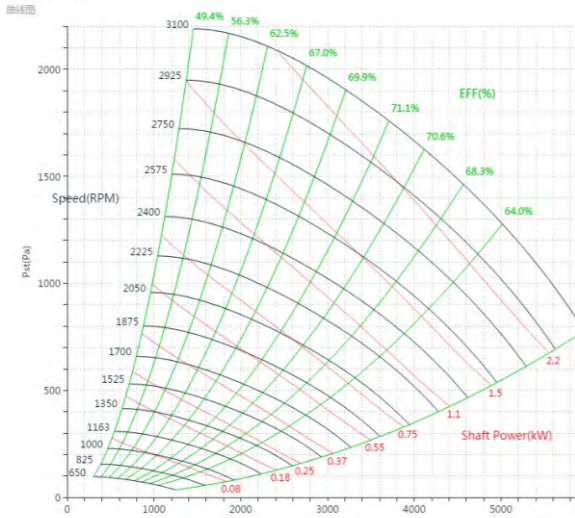

BNS355W70

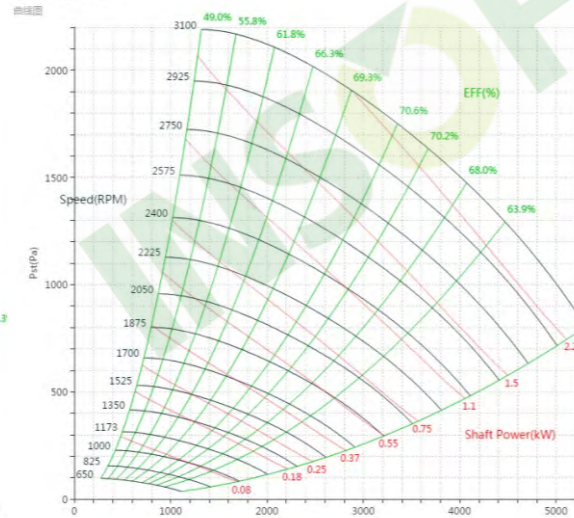

BNS400W80

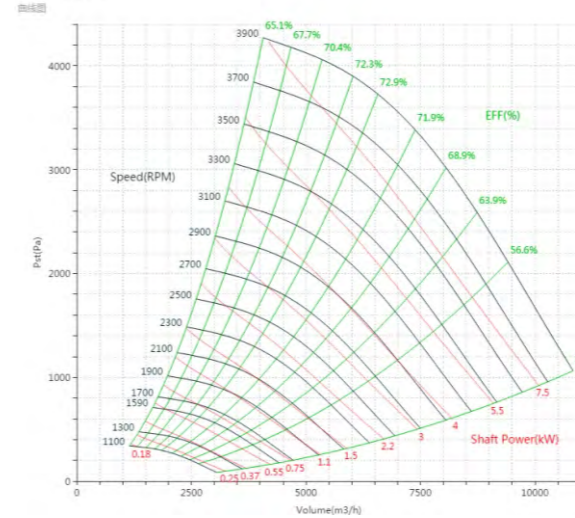

BNS400W70

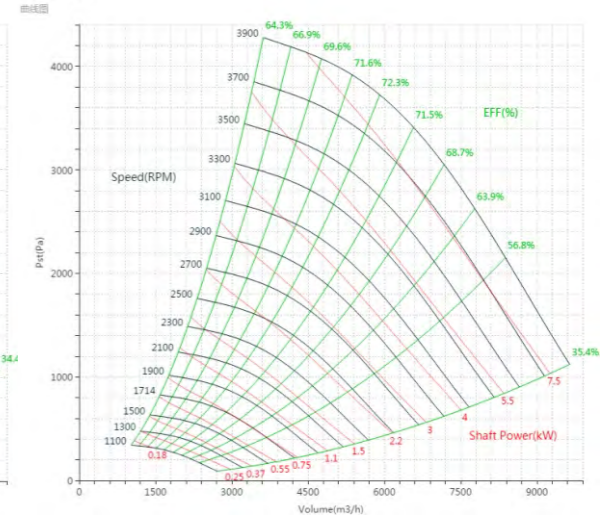

BAS/BNS Series

BAS/BNS Series

标准宽度

BNS450

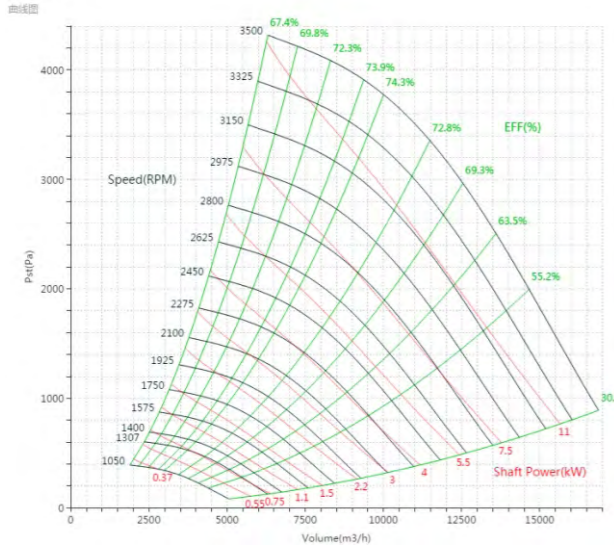

BNS450W90

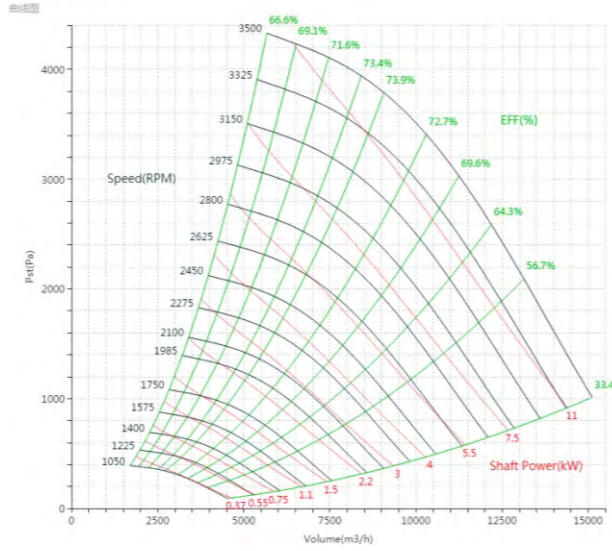

标准宽度

BNS500

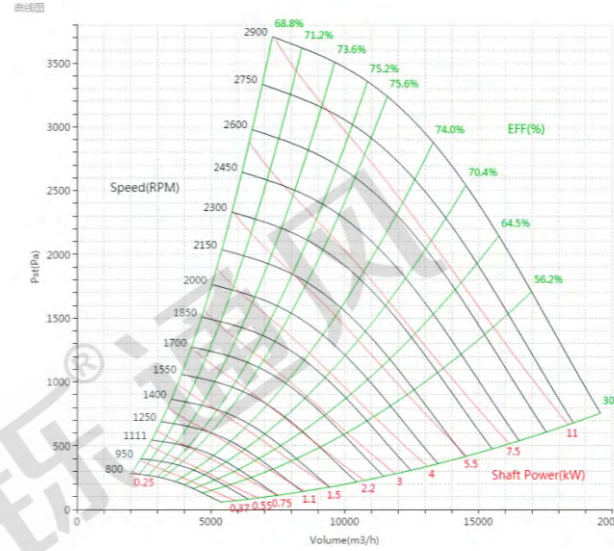

BNS500W90

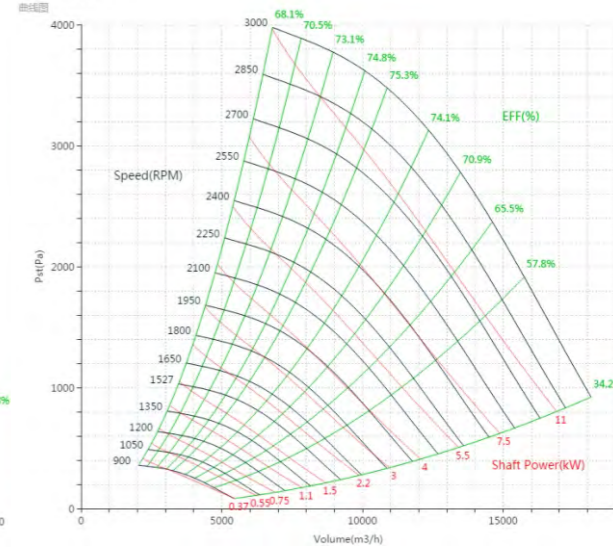

BNS450W80

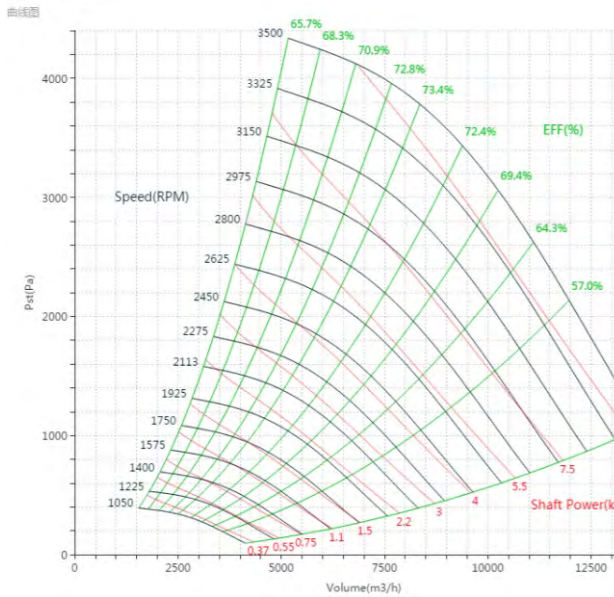

BNS450W70

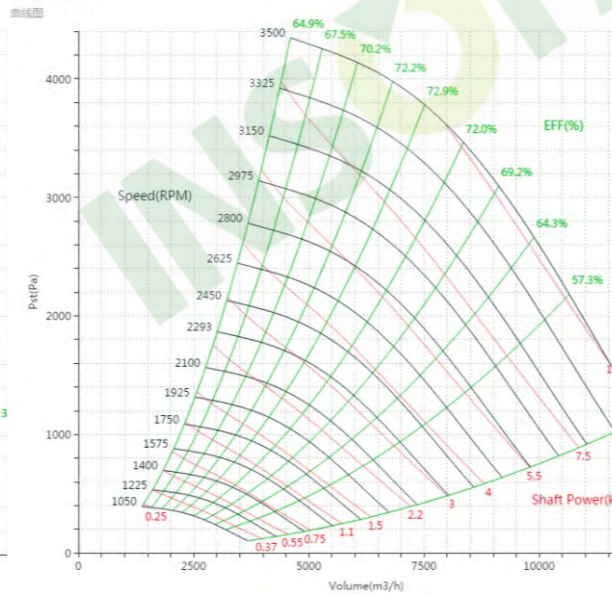

BNS500W80

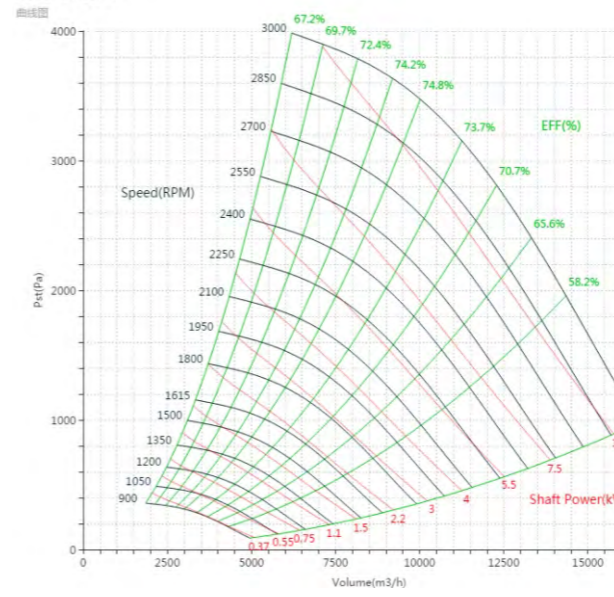

BNS500W70

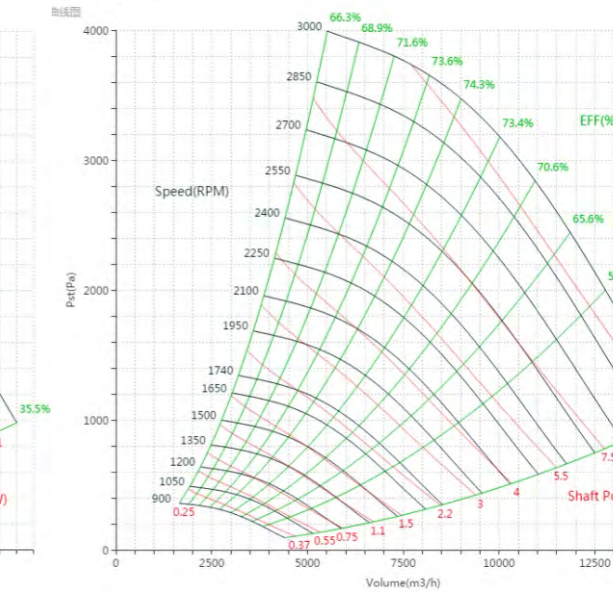

BAS/BNS Series

BAS/BNS Series

标准宽度

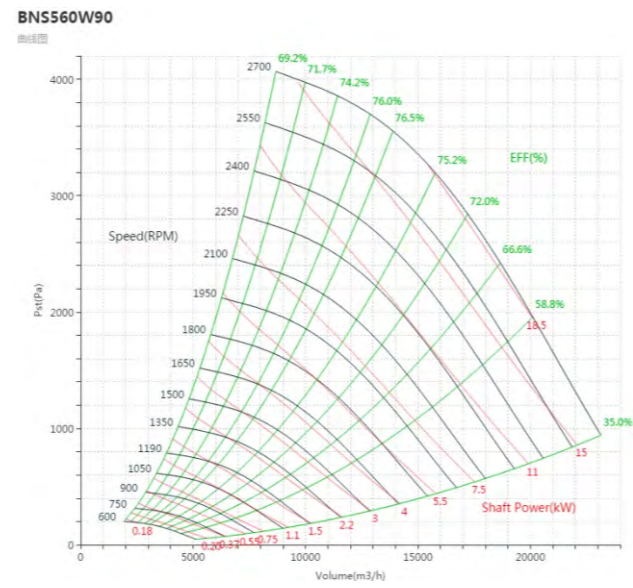
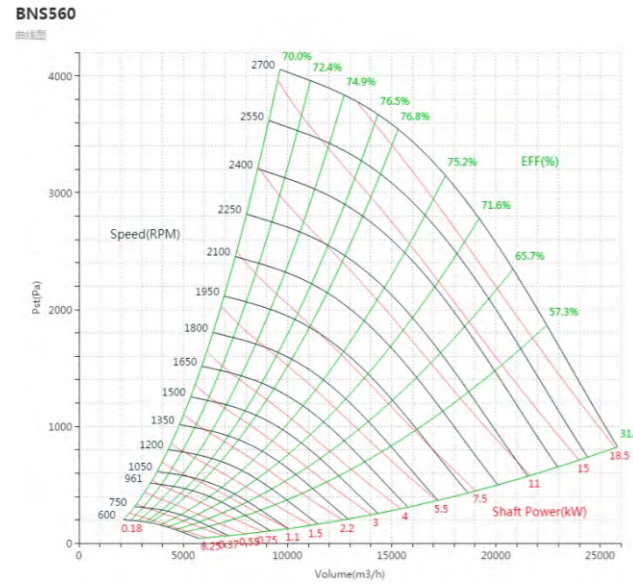

标准宽度

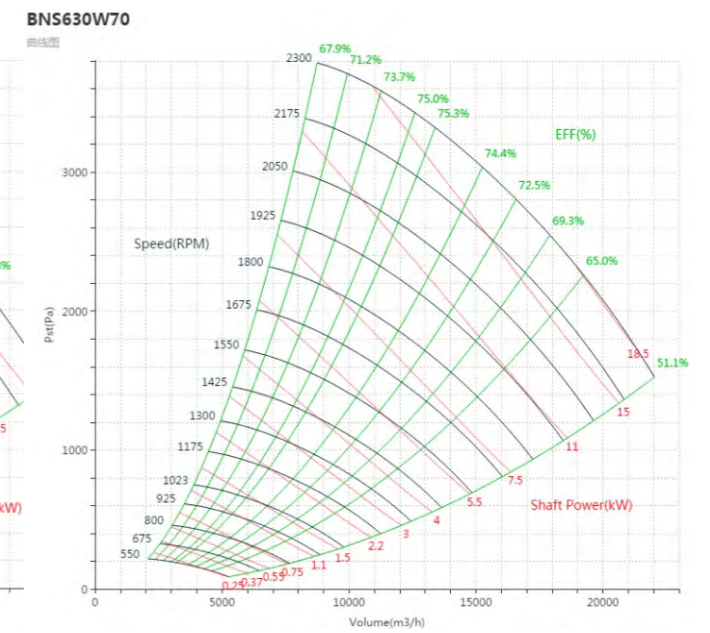
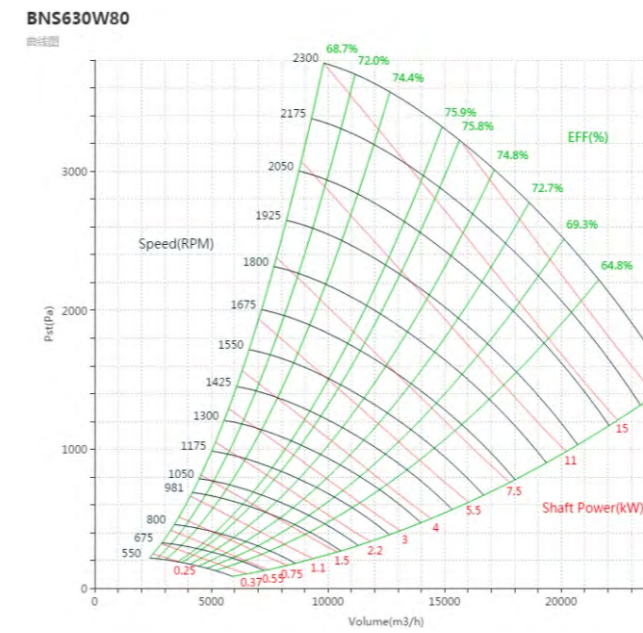
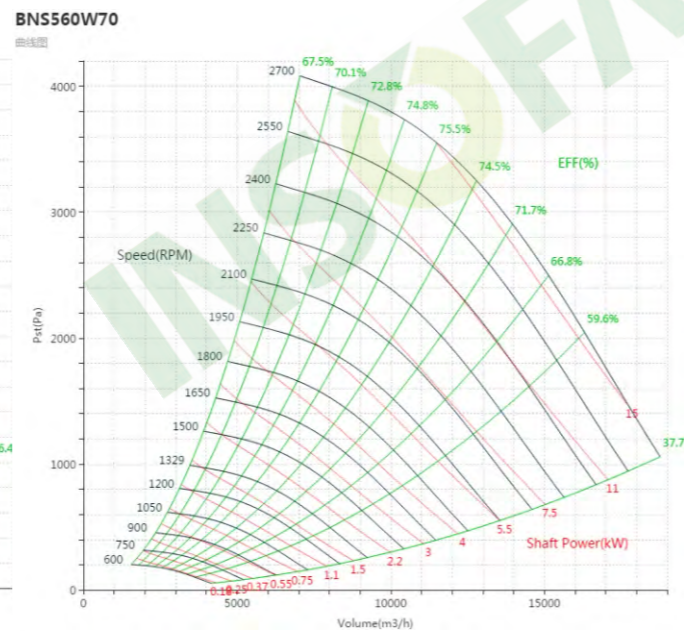
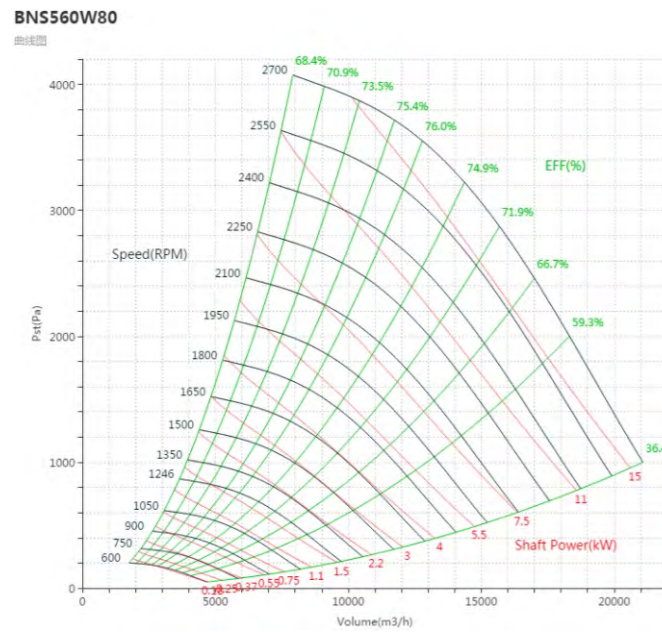
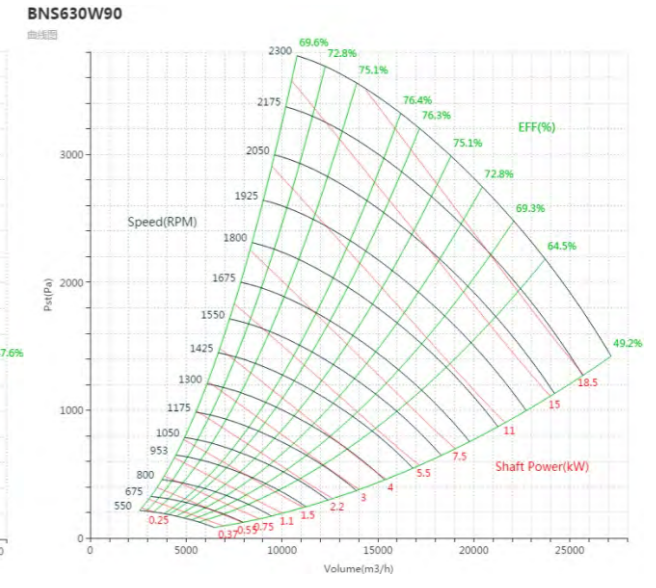
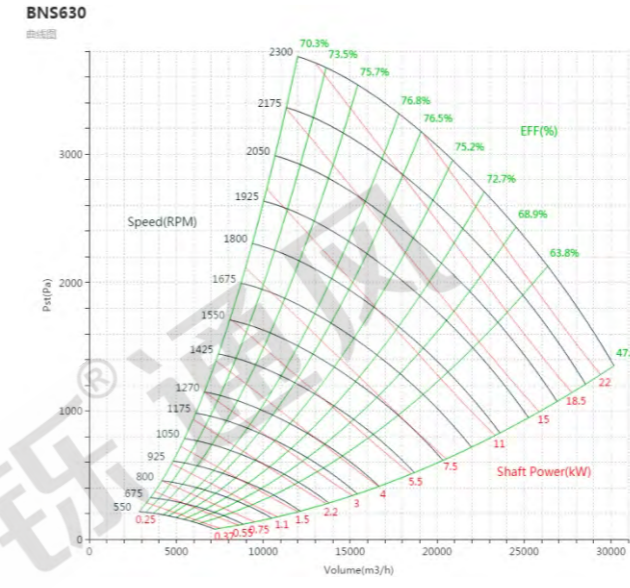

标准宽度

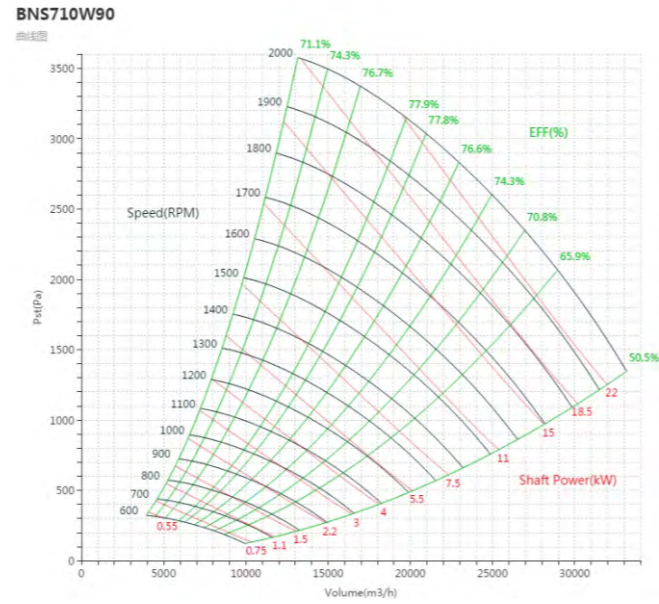
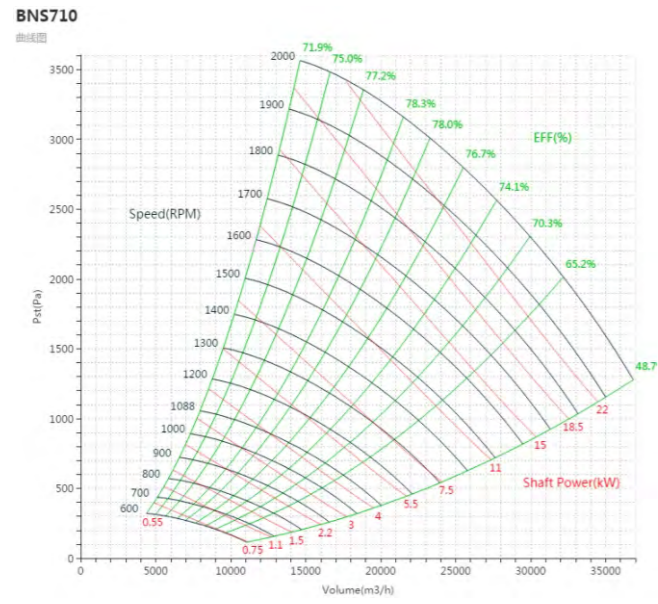

标准宽度

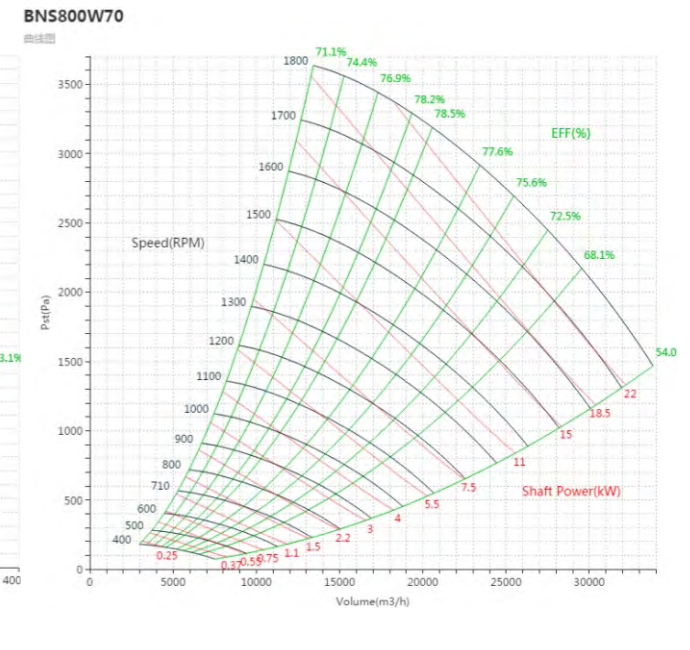
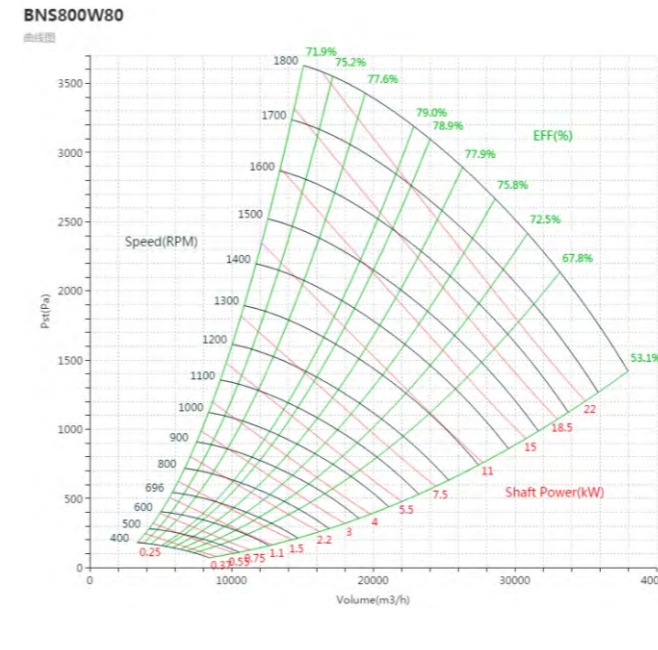
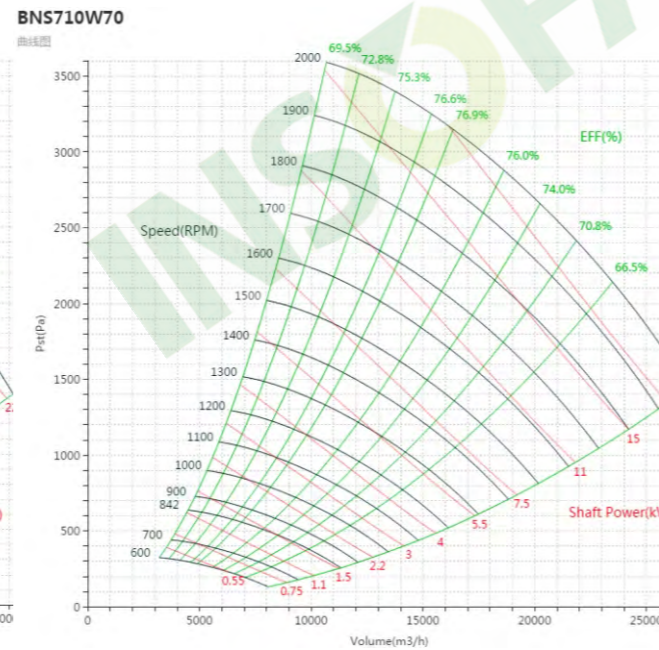
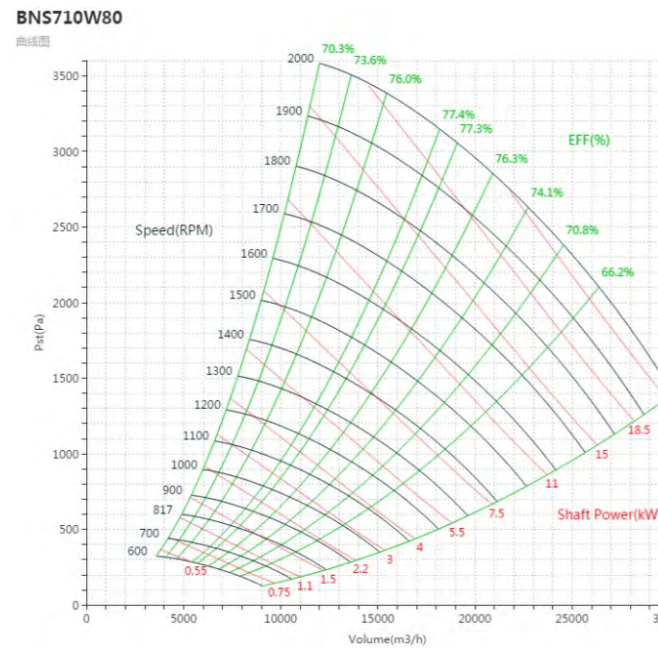
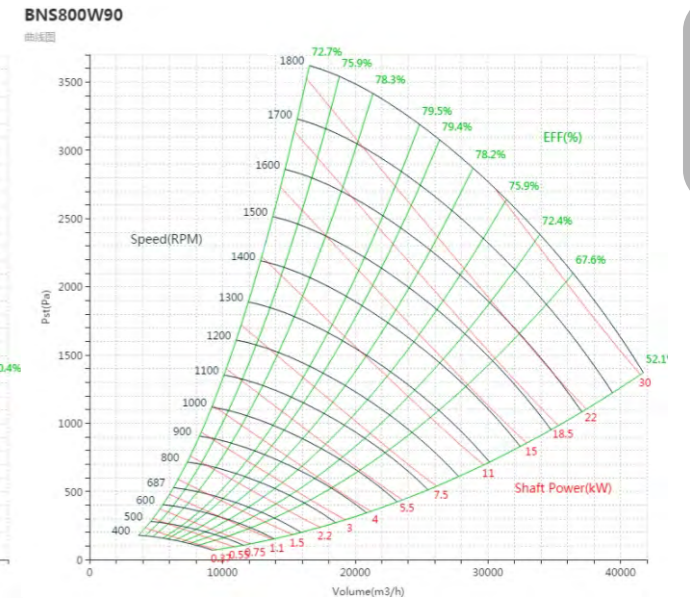

标准宽度

标准宽度

BNS900

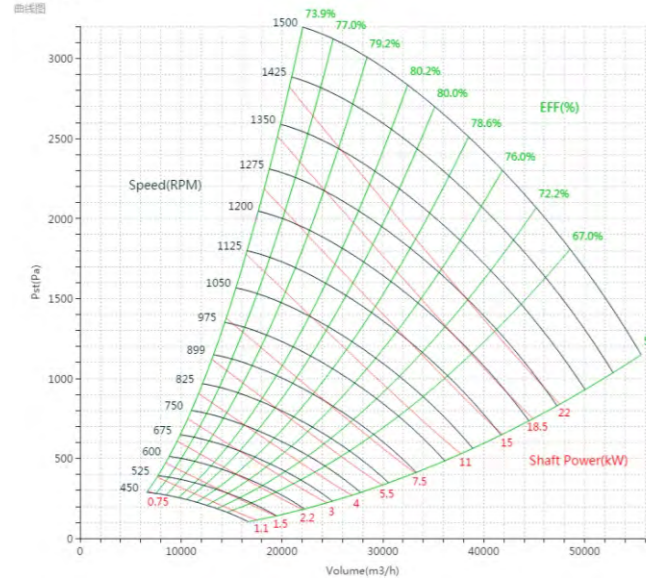

BNS900W90

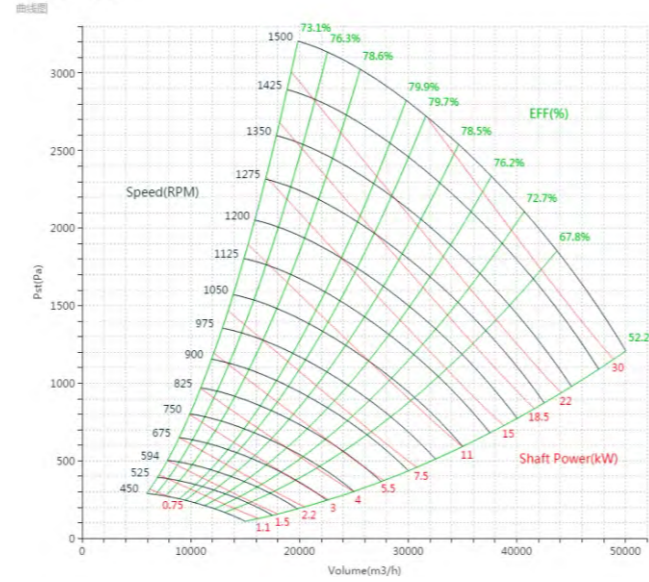

BNS1000

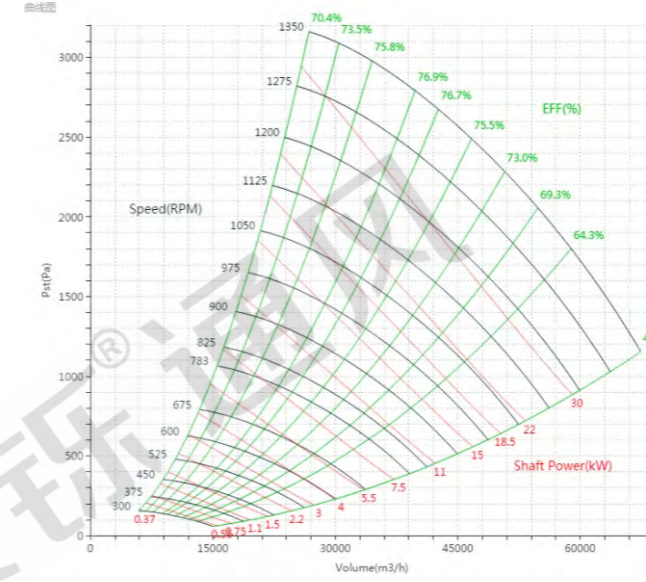

BNS1000W90

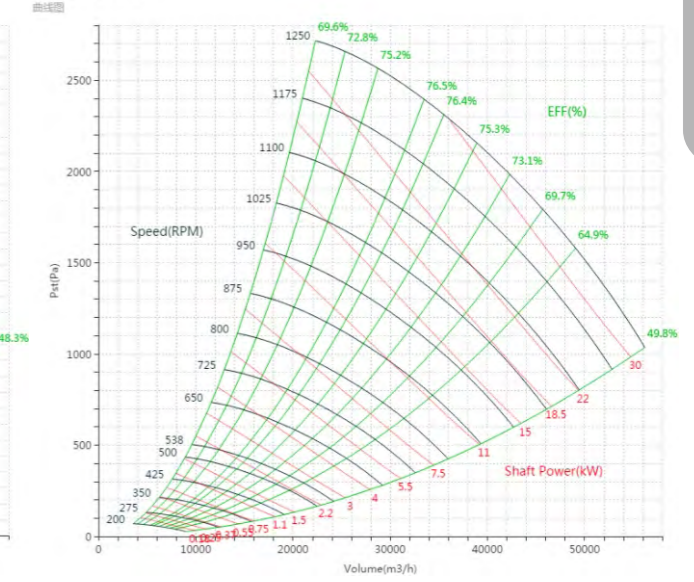

BNS900W80

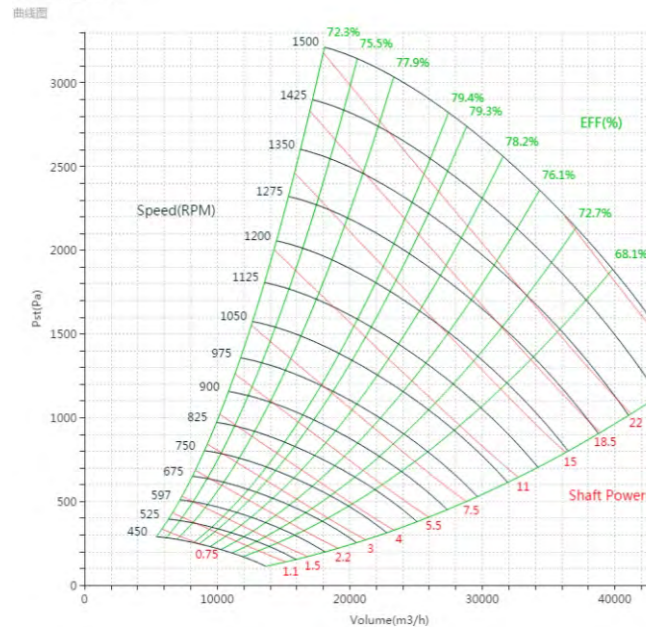

BNS900W70

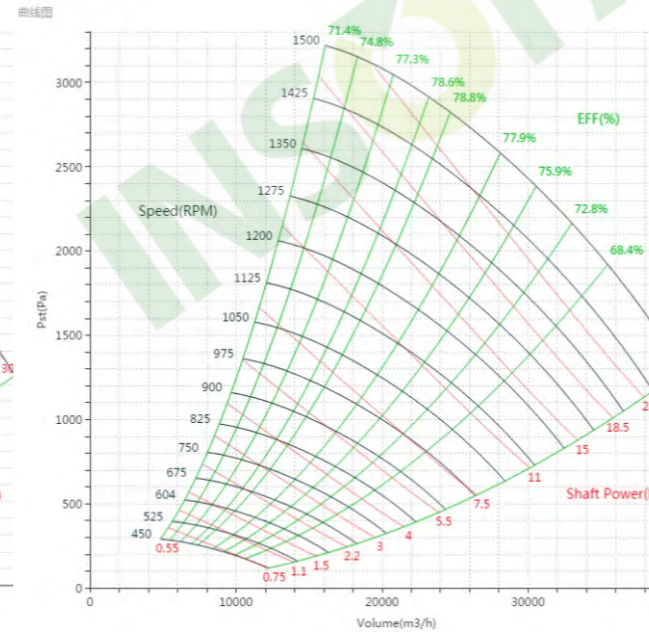

BNS1000W80

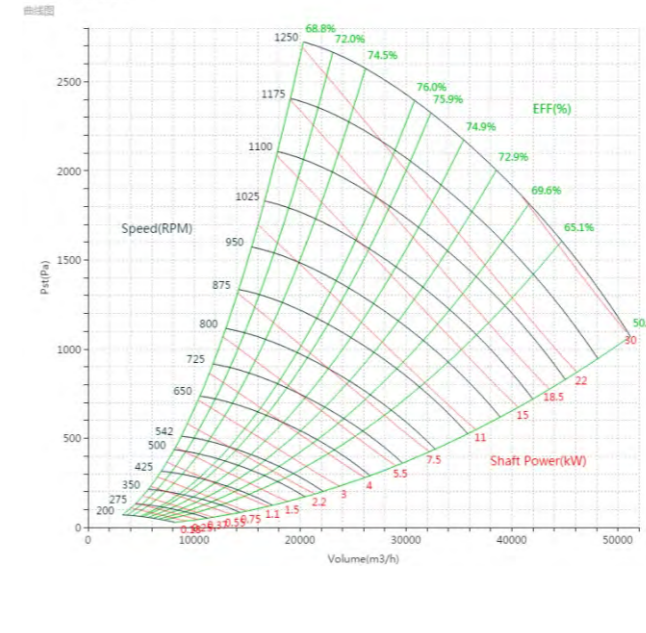

BNS1000W70

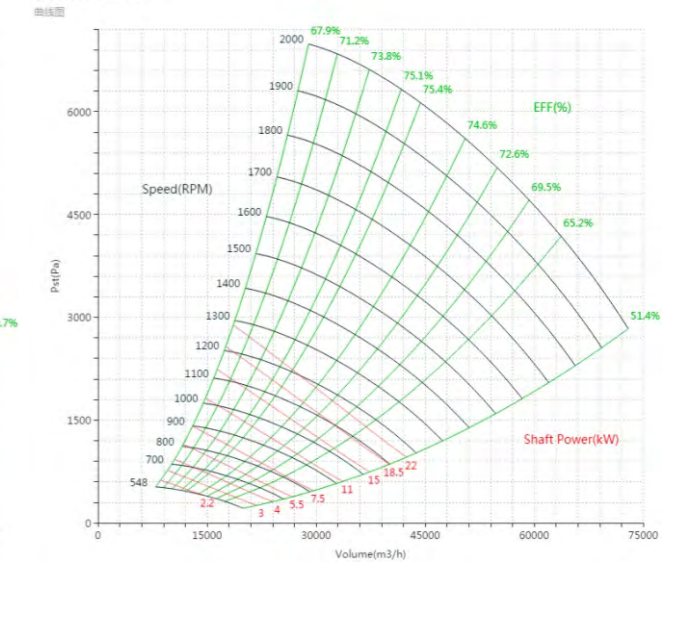

BAS/BNS Series

BAS/BNS Series

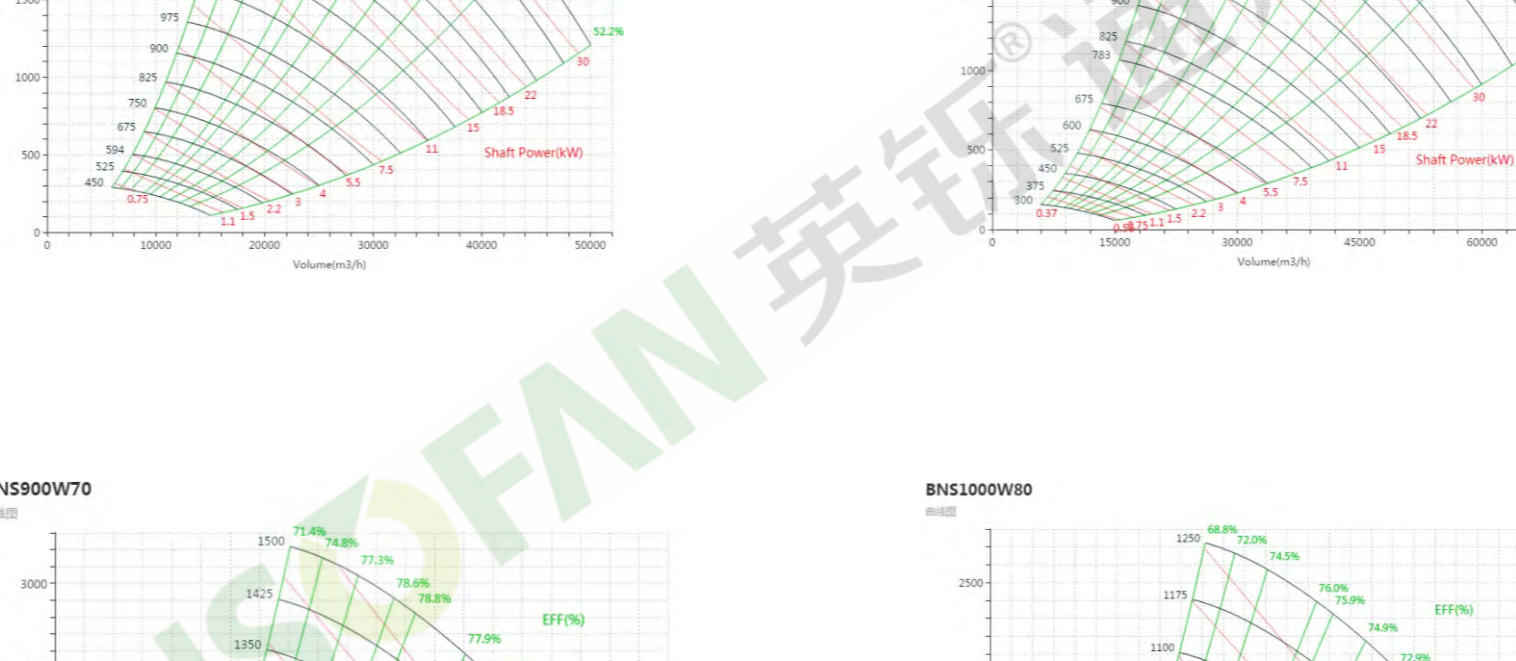

风机安装尺寸 Installation Dimensions

1.MK-方式直联结构尺寸 1. MK-Cube direct driving installation dimension

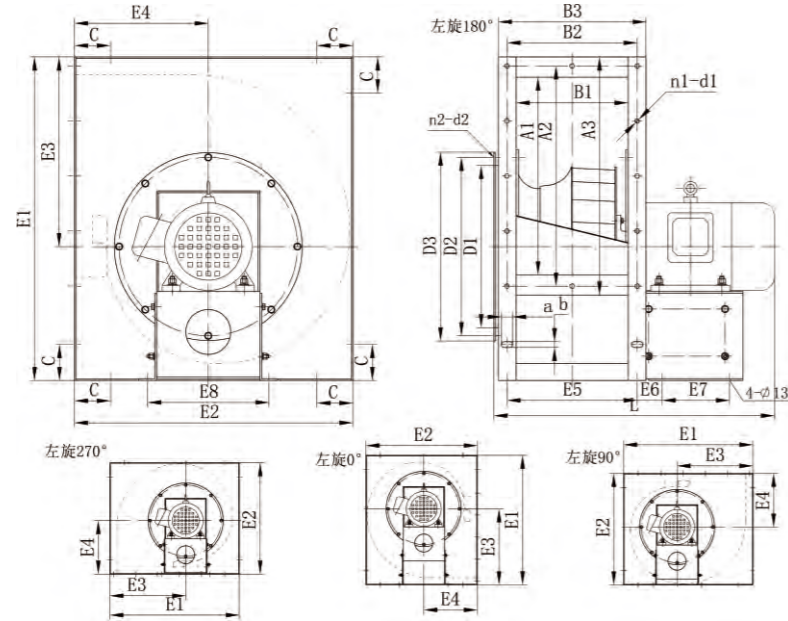

型号	Inlet Dimensions [mm]						Outlet Dimensions [mm]							
Model	D1	D2	D3	N2	D2	A1	A2	A3	B1	B2	B3	N1	D1	D1
250	265	284	308	6	8	316	3×115	375	188	2×116.5	248	10	8	8
280	296	317	343	6	8	345	3×125	405	203	2×124	263	10	8	8
315	332	355	385	6	10	395	4×106.3	455	228	2×136.5	288	12	8	8
355	359	395	425	8	10	446	4×122.5	530	249	2×145	329	12	10	10
400	410	440	470	8	12	496	5×108	580	279	3×107	359	16	10	10
450	459	490	520	8	12	561	5×121	645	309	3×188.3	389	16	10	10
500	510	540	565	8	15	631	5×135	715	349	3×130	429	16	10	10
560	573	610	640	8	15	705	6×125	800	384	4×107.5	474	20	10	10
630	643	680	710	8	15	790	6×140	885	434	4×120	524	20	10	10
710	718	710	795	8	15	885	6×155	978	490	4×134.5	580	20	10	10

型号	配套电机	E1	E2	E3	E4	E5	E6	E7	E8	**L	C	a	b
Model	Motor												
250	0.55-2	515	430	298	205	233	50	110	240	474	60	13	25
280	1.1-2	565	470	330	218	248	50	110	250	590	60	13	25
315	0.55-4	635	530	368	246	273	50	110	240	514	60	13	25
	2.2-2							130	280	560			
355	0.55-4	720	620	422	298	290	55.5	100	240	555	80	13	25
	3-2							150	270	630			
400	0.75-4	810	700	471	339	321	55	110	250	600	120	13	25
	5.5-2							180	320	735			
450	1.5-4	900	780	525	375	355	53	130	260	660	120	13	25
	11-2							280	400	860			
500	2.2-4	990	860	577	413	390	55.5	150	280	735	150	13	25
	15-2							310	400	950			
560	1.1-6	1070	930	647	423	430	58	155	280	775	150	13	25
	4-4							195	350	850			
630	2.2-6	1200	1050	722.5	477.5	480	58	220	370	895	150	13	25
	7.5-4							220	370	935			
710	3-6	1350	1190	808	542	538	58	225	370	995	150	13	25
	11-4							295	400	1050			

\*\* 不同品牌的电机长度不同 Different motor band the dimension 'L' is different

2.DK 风机安装尺寸 2.DK Installation Dimensions

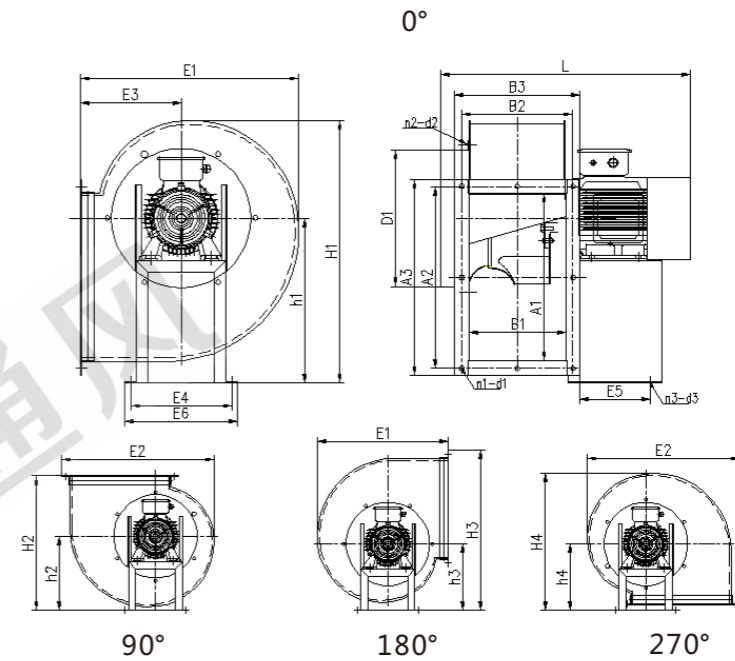

进出风口尺寸 Inlet and outlet dimensions

Model	出风口尺寸							进风口尺寸	
	A1	A2	A3	B1	B2	B3	n1-d1	D1	n2-d2
200	256	286	316	155	185	215	8-φ9	φ206	6-φ9
225	288	318	348	171	201	231	8-φ9	φ232	
250	318	352	382	180	216	246	12-φ9	φ249	
280	356	388	420	200	230	260	12-φ9	φ290	6-φ12
315	400	430	460	234	264	294	14-φ9	φ324	
355	446	490	531	249	290	329	12-φ12	φ366	8-φ12
400	497	541	582	275	316	355	12-φ12	φ414	
450	557	601	642	305	346	410	12-φ12	φ461	

外形安装尺寸 Installation dimensions

Model	电机机座号	外形安装尺寸																
		L max	H1	H2	H3	H4	h1	h2	h3	h4	E1	E2	E3	E4	E5	E5 (270)	E6	n3-d3
200	80M	461	426	360	435	369	270	190	190	190	348	398	164	215	150	120	240	4-φ10
225	80M/90S/90L	517	466	396	482	413	290	210	210	210	388	444	180	215	150	120	240	4-φ10
250	80M/90S/90L	535	510	436	534	460	316	236	236	236	423	488	194	215	150	120	240	4-φ10
280	80M/90S/90L/100L	613	565	483	589	507	349	263	258	256	470	542	214	255	230	200	280	4-φ10
315	80M/90S/90L/100L	649	629	536	652	560	388	294	283	278	523	606	236	255	230	200	280	4-φ10
355	80M/90S/90L/100L	673	702	607	724	633	431	330	313	313	594	678	271	255	230	200	280	4-φ10
400	80M/90S/90L/100L	739	782	665	806	690	479	369	345	332	654	760	290	330	230	200	355	4-φ10
	112M/132S																	
450	80M/90S/90L/100L	785	874	742	898	766	533	414	383	364	731	852	322	330	230	200	355	4-φ10
	112M/132S/132M																	

\*\* 不同品牌的电机长度不同 "Lmax" 不同 Different motor band the dimension 'Lmax' is different

90°、180°和270°除图中标示出的尺寸外，其余与0°相同

Except to the size of the diagram of 90°, 180° and 270°, the rest is the same as the 0°

> 3. RMF-悬挂式/立式结构

3. RMF- hanging installation/Vertical installation

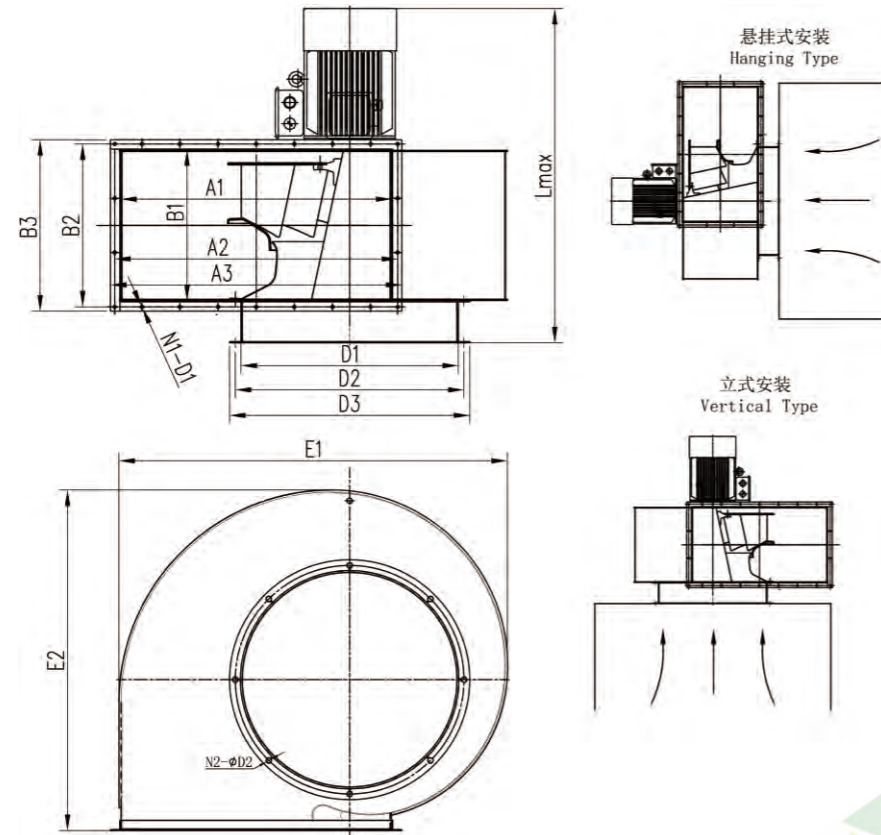

型号	电机		Inlet Dimensions [mm]					Outlet Dimensions [mm]							
Model	Motor	Lmax	D2	D3	N2	D2	A1	A2	A3	B1	B2	B3	N1	D1	D1
250	0.75-2	496	284	308	6	8	316	3×115	376	188	2×116.5	248	10	8	8
280	1.1-2	511	317	343	6	8	345	3×125	405	203	2×124	263	10	8	8
315	2.2-2	589	355	385	6	10	395	4×106.3	455	228	2×136.5	288	12	8	8
355	3-2	650	395	425	8	10	446	4×122.5	516	249	2×145	319	12	10	10
400	5.5-2	749	440	470	8	12	496	5×108	566	279	3×107	349	16	10	10
450	1.5-4	695	490	520	8	12	561	5×121	631	309	3×188.3	379	16	10	10
500	2.2-4	769	540	565	8	15	631	5×135	701	349	3×130	419	16	10	10
560	4-4	798	610	640	8	15	705	6×125	785	384	4×107.5	464	20	10	10
630	7.5-4	959	680	710	8	15	790	6×140	870	434	4×120	514	20	10	10
710	11-4	1074	710	795	8	15	885	6×155	965	490	4×134.5	570	20	10	10

\*\* 不同品牌的电机 'Lmax' 长度不同 Different motor band the dimension 'Lmax' is different

> 4.RF 风机安装尺寸

4.RF Installation Dimensions

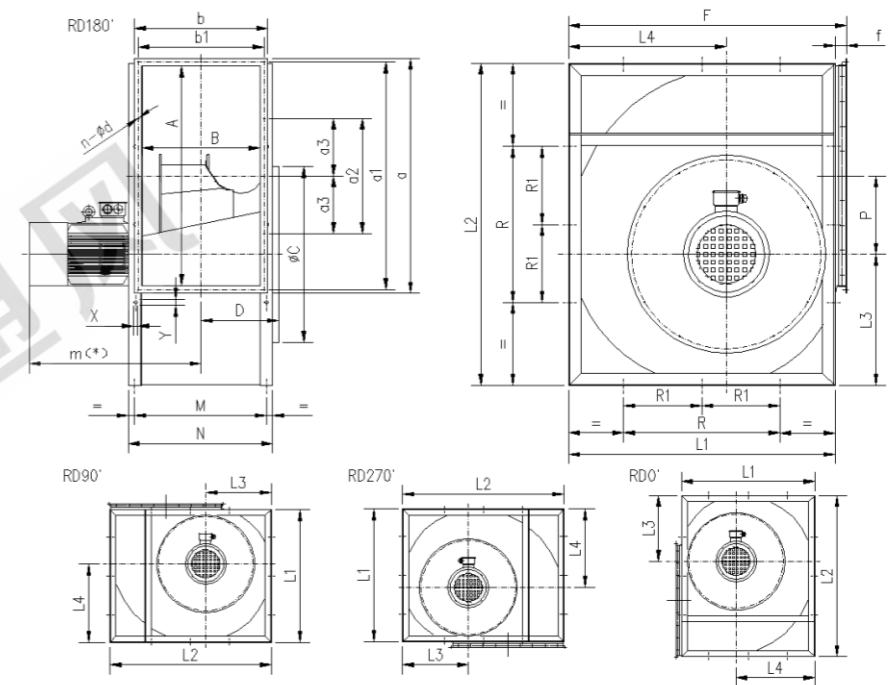

Model	Motor	L1	L2	L3	L4	R	R1	F	f	N	M	*m	P
250	0.75-2	384	461	187	224	224	∕	419	35	254	219	343	109
280	1.1-2	432	518	211	251	280	∕	466	34	268	238	350	121.5
315	2.2-2	480	578	235	282	280	∕	518	38	294	264	405	138
355	3-2	548	654	265	318	315	∕	578	32	336	296	462	157
400	5.5-2	612	736	299	360	355	∕	650	38	364	324	544	179
450	1.5-4	681	827	336	404	400	∕	726	45	393	353	446	202
500	2.2-4	750	918	375	448	450	∕	800	50	425	380	507	219
560	4-4	844	1030	420	502	∕	250	892	48	487	437	530	245.5
630	7.5-4	945	1157	472	564	∕	280	998	53	530	480	663	278
710	7.5-4	1075	1302	530	636	∕	315	1120	45	583	533	689	317

Model	A	B	C	D	a	a1	a2	a3	b	b1	n	d	X	Y
250	322	191	254	157	381	351	∕	∕	250	220	4	9	11	16
280	362	206	290	164.5	422	392	∕	∕	266	236	8	9	13	18
315	405	231	324	177	465	435	∕	∕	291	261	8	9	13	18
355	453	253	362	188	513	483	∕	∕	313	283	8	9	13	18
400	507	281	415	202	567	537	∕	∕	341	311	8	9	13	18
450	569	310	462	216.5	629	599	∕	∕	370	340	8	9	13	18
500	639	341	511	242	699	669	∕	∕	401	371	8	9	13	18
560	715	383	575	263	775	744.5	248	∕	443	413	10	9	13	18
630	801	425	646	285	861	831	276	∕	485	455	10	9	13	18
710	889	478	714	312	949	919	465	232.5	538	508	12	9	17	22

\*\*不同品牌的电机长度不同 \*\*m' 不同 Different motor band the dimension '\*m' is different

➤ 5.RF 风机安装尺寸  
5. RF Installation Dimensions

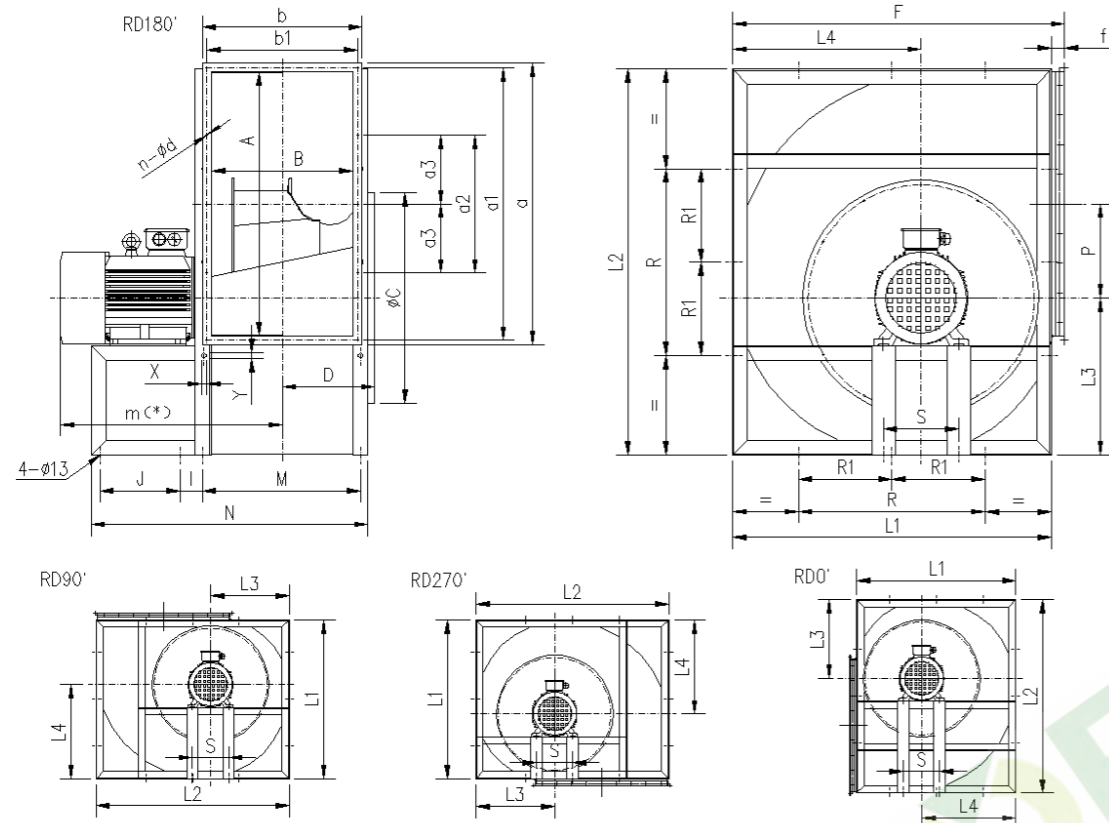

Model	Motor	L1	L2	L3	L4	R	R1	F	f	N	M	J	I	S	*m
400	160M	612	736	299	360	355		650	38	364	324	270	75	254	649
450	160M	681	827	336	404	400		726	45	393	353	270	75	254	666
500	160M	750	918	375	448	450		800	50	425	380	270	75	254	679
560	160L	844	1030	420	502		250	892	48	487	437	270	75	254	762
630	160L	945	1157	472	564		280	998	53	530	480	270	75	254	786
710	180M	1075	1302	530	636		315	1120	45	583	533	320	75	279	810

Model	A	B	C	D	a	a1	a2	a3	b	b1	P	n	d	X	Y
400	507	281	415	202	567	537			341	311	179	8	9	13	18
450	569	310	462	216.5	629	599			370	340	202	8	9	13	18
500	639	341	511	242	699	669			401	371	219	8	9	13	18
560	715	383	575	263	775	744.5	248		443	413	245.5	10	9	13	18
630	801	425	646	285	861	831	276		485	455	278	10	9	13	18
710	889	478	714	312	949	919	465	232.5	538	508	317	12	9	17	22

\*\*不同品牌的电机长度不同 “\*m” 不同 Different motor band the dimension “\*m” is different

➤ 6.RFC1 风机安装尺寸  
6.RFC1 Installation Dimensions

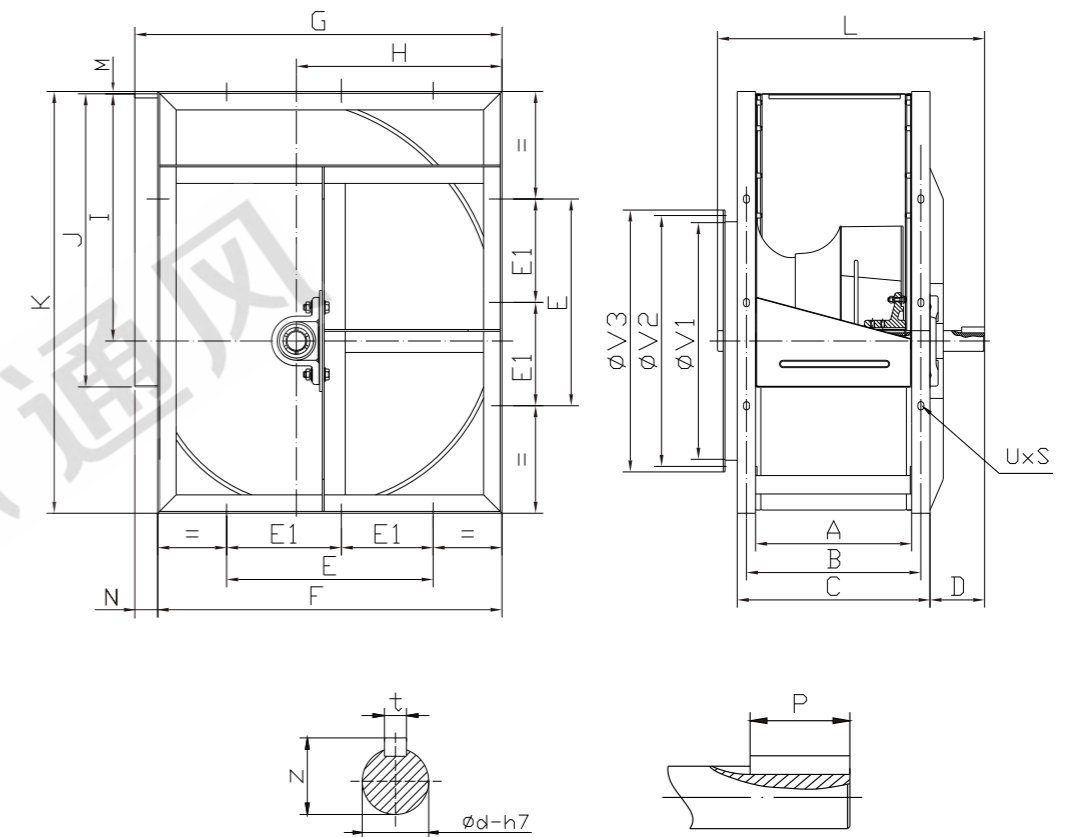

[mm]

Model	A	B	C	D	E	E1	F	G	H	I	J	K	L	M	N	φV1	φV2	φV3	φd	t	z	P	UXS
200	155	180	215	77	224		306	343	179	215	256	370	332	4	37	202	223	242	25	8	28.3	40	11X16
225	173	198	233	81	224		348	383	203	243	288	415	354	3	35	228	250	268	25	8	28.3	40	11X16
250	190	215	250	79	224		384	419	224	270	322	461	369	4	35	250	274	290	25	8	28.3	40	11X16
280	205	235	265	77	280		432	466	251	302	361	518	382	5	34	286	314	332	25	8	28.3	40	11X16
315	230	260	290	80	280		480	518	282	340	404	578	415	3	38	320	356	380	25	8	28.3	40	13X18
355	252	292	332	93	315		548	578	318	383	452	654	460	6	30	362	397	420	25	8	28.3	40	13X18
400	280	320	360	93	355		612	650	360	432	506	736	490	5	38	410	438	464	30	8	33.3	50	13X18
450	309	349	389	115	400		681	726	404	486	586	827	542	5	45	457	490	520	35	10	38.3	50	13X18
500	340	380	420	119	450		750	800	448	538	638	918	582	5	50	506	546	570	35	10	38.3	70	13X18
560	382	432	482	133		250	844	892	502	603	714	1030	650	7	48	570	600	636	40	12	43.3	70	13X18
630	425	475	525	133		280	945	998	564	679	800	1157	700	6	53	641	580	710	45	14	48.5	90	13X18
710	478	528	578	141		315	1075	1120	636	765	898	1302	758	7	63	709	762	800	45	14	48.5	90	17X22
800	535	585	635	141		355	1180	1254	714	862	1006	1468	838	7	74	801	860	900	50	14	53.5	90	17X22
900	600	650	700	158		400	1319	1408	804	971	1130	1648	920	7	89	906	966	1006	50	14	53.5	90	17X22
1000	673	733	799	179		450	1450	1540	884	1066	1266	1810	1046	9	90	1016	1074	1110	55	16	59	90	17X22

说明：所有尺寸允许偏差±4mm  
Note: Overall dimension tolerance arange ±4mm.

> 7.RFC2 风机安装尺寸(不包含底座)

7. RFC2 Installation Dimensions (Without basic frame)

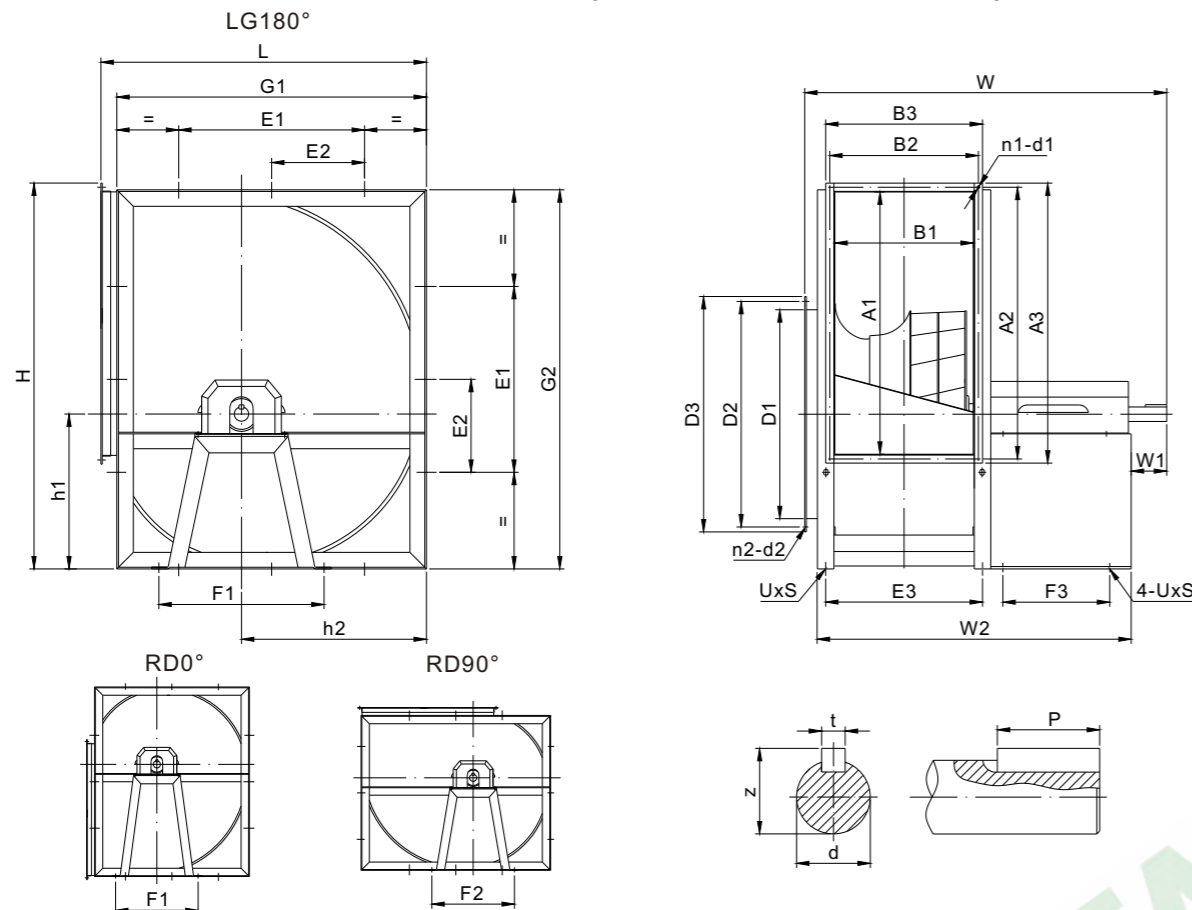

Model	A1	A2	A3	B1	B2	B3	n1-d1	D1	D2	D3	n2-d2	E1	E2	E3	U×S
280	361	391	421	205	235	265	8-Φ9	Φ286	Φ314	Φ332	6-Φ10	280	/	235	11×16
315	404	434	464	230	260	290	8-Φ9	Φ320	Φ356	Φ380	6-Φ10	280	/	260	13×18
355	452	482	512	252	282	312	8-Φ9	Φ362	Φ397	Φ420	8-Φ10	315	/	292	13×18
400	506	536	566	280	310	340	8-Φ9	Φ410	Φ438	Φ464	8-Φ10	355	/	320	13×18
450	568	598	628	309	339	369	8-Φ9	Φ457	Φ490	Φ520	8-Φ10	400	/	349	13×18
500	638	668	698	340	370	400	8-Φ9	Φ506	Φ546	Φ570	8-Φ10	450	/	380	13×18
560	714	744	774	382	412	442	10-Φ9	Φ570	Φ600	Φ636	8-Φ12	500	250	432	13×18
630	800	830	860	425	455	485	10-Φ9	Φ640	Φ680	Φ710	8-Φ12	560	280	475	13×18
710	898	928	958	478	508	538	12-Φ9	Φ705	Φ762	Φ800	12-Φ13	630	315	528	17×22
800	1006	1036	1066	535	565	595	12-Φ9	Φ805	Φ860	Φ900	12-Φ13	710	355	585	17×22
900	1130	1160	1190	600	630	660	18-Φ9	Φ905	Φ966	Φ1006	12-Φ13	800	400	650	17×22
1000	1266	1296	1326	673	703	733	18-Φ9	Φ1005	Φ1074	Φ1110	12-Φ13	900	450	733	17×22

Model	F1	F2	F3	G1	G2	H	h1	h2	L	W	W1	W2	d	t	z	P
280	318	308	208	432	518	543	211	251	466	616	62	524	25	8	28.3	40
315	282	292	220	480	578	605	235	282	518	655	63	563	25	8	28.3	40
355	351	389	240	548	654	678	265	318	578	721	70	632	30	8	33.3	50
400	371	403	240	612	736	761	299	360	650	751	70	660	30	8	33.3	50
450	385	407	300	681	827	852	336	404	726	838	88	729	35	10	38.3	70
500	402	402	300	750	918	943	375	448	800	877	86	760	35	10	38.3	70
560	444	444	300	844	1030	1053	420	502	892	965	90	854	40	12	43.3	70
630	510	460	330	945	1157	1181	472	564	998	1009	90	898	40	12	43.3	70
710	510	510	390	1075	1302	1325	530	636	1120	1140	110	1008	45	14	48.5	90
800	630	584	394	1180	1468	1491	599	714	1254	1211	110	1070	45	14	48.5	90
900	717	648	456	1319	1648	1670	670	804	1408	1356	120	1205	55	16	59	90
1000	760	760	456	1450	1810	1831	735	884	1540	1434	120	1296	55	16	59	90

> 8.RFC2 风机安装尺寸(包含底座)

8. RFC2 Installation Dimensions (Include basic frame)

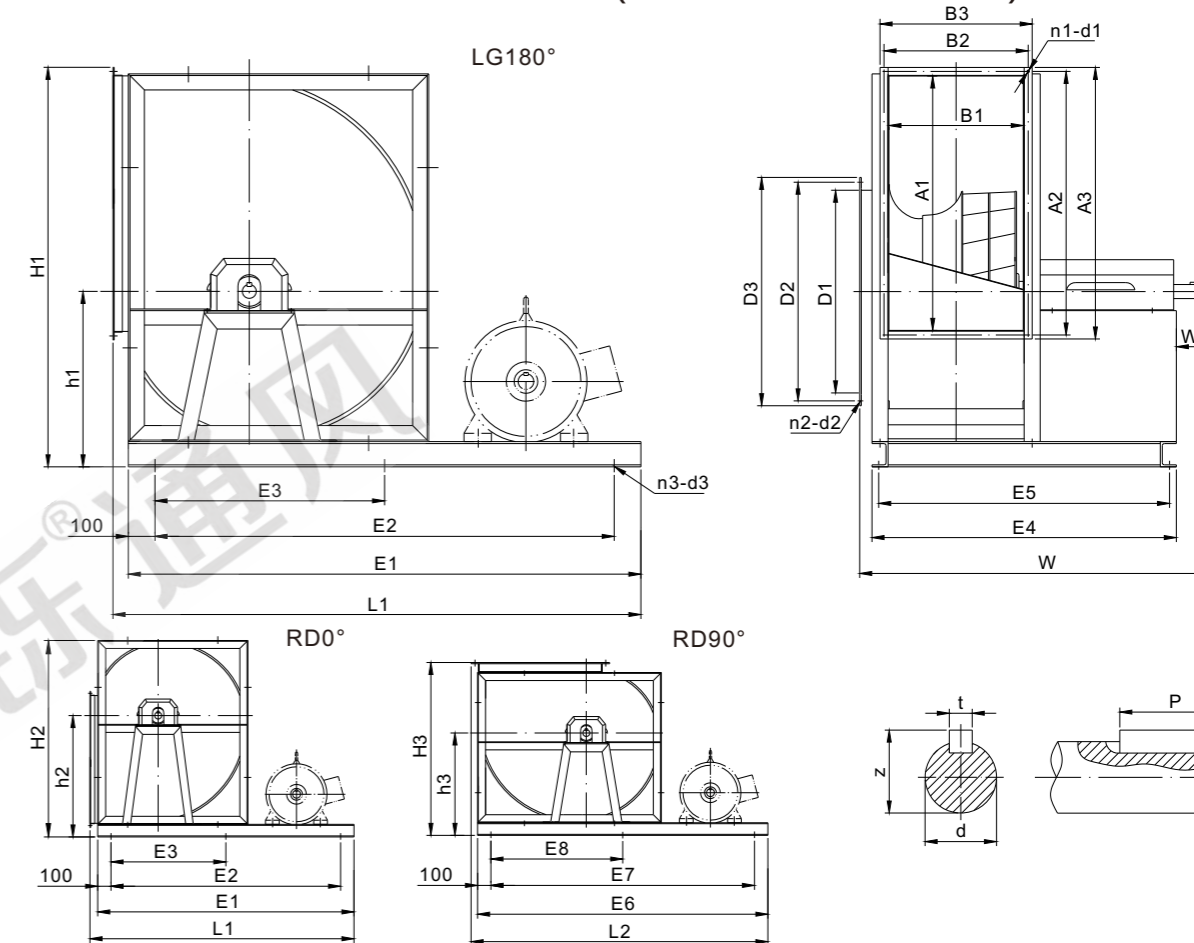

Model	A1	A2	A3	B1	B2	B3	n1-d1	D1	D2	D3	n2-d2	H1	H2	H3	h1	h2	h3
280	361	391	421	205	235	265	8-Φ9	Φ286	Φ314	Φ332	6-Φ10	593	568	516	261	357	301
315	404	434	464	230	260	290	8-Φ9	Φ320	Φ356	Φ380	6-Φ10	655	628	568	285	393	332
355	452	482	512	252	282	312	8-Φ9	Φ362	Φ397	Φ420	8-Φ10	728	704	628	315	439	368
400	506	536	566	280	310	340	8-Φ9	Φ410	Φ438	Φ460	8-Φ10	811	786	700	349	487	410
450	568	598	628	309	339	369	8-Φ9	Φ457	Φ490	Φ520	8-Φ10	902	877	776	386	541	454
500	638	668	698	340	370	400	8-Φ9	Φ506	Φ546	Φ570	8-Φ10	1006	981	863	438	606	511
560	714	744	774	382	412	442	10-Φ9	Φ570	Φ600	Φ636	8-Φ12	1116	1093	955	483	673	565
630	800	830	860	425	455	485	10-Φ9	Φ640	Φ680	Φ710	8-Φ12	1244	1220	1061	535	748	627
710	898	928	958	478	508	538	12-Φ9	Φ705	Φ762	Φ800	12-Φ13	1405	1382	1200	610	852	716
800	1006	1036	1066	535	565	595	12-Φ9	Φ805	Φ860	Φ900	12-Φ13	1571	1548	1334	679	949	794
900	1130	1160	1190	600	630	660	18-Φ9	Φ905	Φ966	Φ1006	12-Φ13	1770	1748	1508	770	1078	904
1000	1266	1296	1326	673	703	733	18-Φ9	Φ1005	Φ1074	Φ1110	12-Φ13	1931	1910	1640	835	1175	984

Model	L1	L2	W	W1	E1	E2	E3	E4	E5	E6	E7	E8	n3-d3	d	t	z	P
280	834	910	616	62	800	600	/	524	494	885	685	/	4-Φ14	25	8	28.3	40
315	938	1027	655	62	900	700	/	563	533	1000	800	/	4-Φ14	25	8	28.3	40
355	1030	1124	721	70	1000	800	/	632	602	1100	900	/	4-Φ14	30	8	33.3	50
400	1138	1225	751	70	1100	900	/	655	625	1200	1000	/	4-Φ14	30	8	33.3	50
450	1245	1385	838	88	1200	1000	/	724	694	1360	1160	/	4-Φ14	35	10	38.3	70
500	1330	1475	877	86	1280	1080	/	760	720	1450	1250	/	4-Φ14	35	10	38.3	70
560	1448	1623	965	90	1400	1200	600	850	810	1600	1400	700	6-Φ14	40	12	43.3	70
630	1595	1773	1009	90	1540	1340	670	896	853	1750	1550	775	6-Φ14	40	12	43.3	70
710	1763	1973	1140	110	1700	1500	750	1006	963	1950	1750	875	6-Φ18	45	14	48.5	90
800	1924	2123	1211	110	1850	1650	825	1068	1025	2100	1900	950	6-Φ18	45	14	48.5	90
900	2039	2322	1356	120	1950	1750	875	1208	1160	2300	2100	1050	6-Φ18	55	16	59	90
1000	2150	2441	1434	120	2060	1860	930	1290	1243	2420	2220	1110	6-Φ18	55	16	59	90